

MECHlift ML325 & ML325K Bin Lifter

BOLT-ON MODEL



Spare Parts Catalogue

- See page 2 for delivery arrangements -



Invoice values of R30,000 and above qualify for free delivery within the borders of South Africa. Delivery is by economy road freight only and may take several days.

NEEDING PARTS SOONER, PLEASE ARRANGE YOUR OWN COURIER AT YOUR OWN COST.

CONTENT

IDENTIFYING the lifter, finding its Model and Serial Number

... ML 325 Bin Lifter Assembly – 240litre to 700litre bins.....	4
...ML 325K Bin Lifter Assembly – 240litre to 1100litre bins.....	5

Lifter Sub Assembly QUICK REFERENCE GUIDE6

... NOTES page	7
Fulcrum Arm and Hub Assemblies LH & RH	8
Coupling.....	10
H Frame	11
Comb Frame	12
Long Link Rod.....	13
Lower Link Frame	14
Swing Frame.....	15

Main Frame

Main Frame Assembly.....	16
Upper Stop Bracket.....	18
Coupling Retainer	19
Fulcrum Lock.....	20
Guard Frame – LH	21
Guard Frame – RH.....	22
Stopper Bar.....	23
Lid Opener	24
Lid Opener Control Mechanism.....	25
Bin Opener Pull Back Kit.....	26
Klaparms.....	27

Hydraulics

Hydraulic System	28
Actuator Service Parts.....	30

Note to Partsman:

- Always quote the Mechlif part numbers when ordering parts
- Part numbers ending in 1 usually refer to Left Hand Side parts
- Part numbers ending in 2 usually refer to Right Hand Side parts
- If in doubt, please feel free to contact Mechlif, we are always willing to assist

ML 325 BIN LIFTER ASSEMBLY

Part Number: 35 00 100 A

THE ML325 HAS A FIXED BIN STOPPER BAR FOR MAXIMUM 700litre TYPE BINS ONLY AND HAS NO LIFTING ARMS

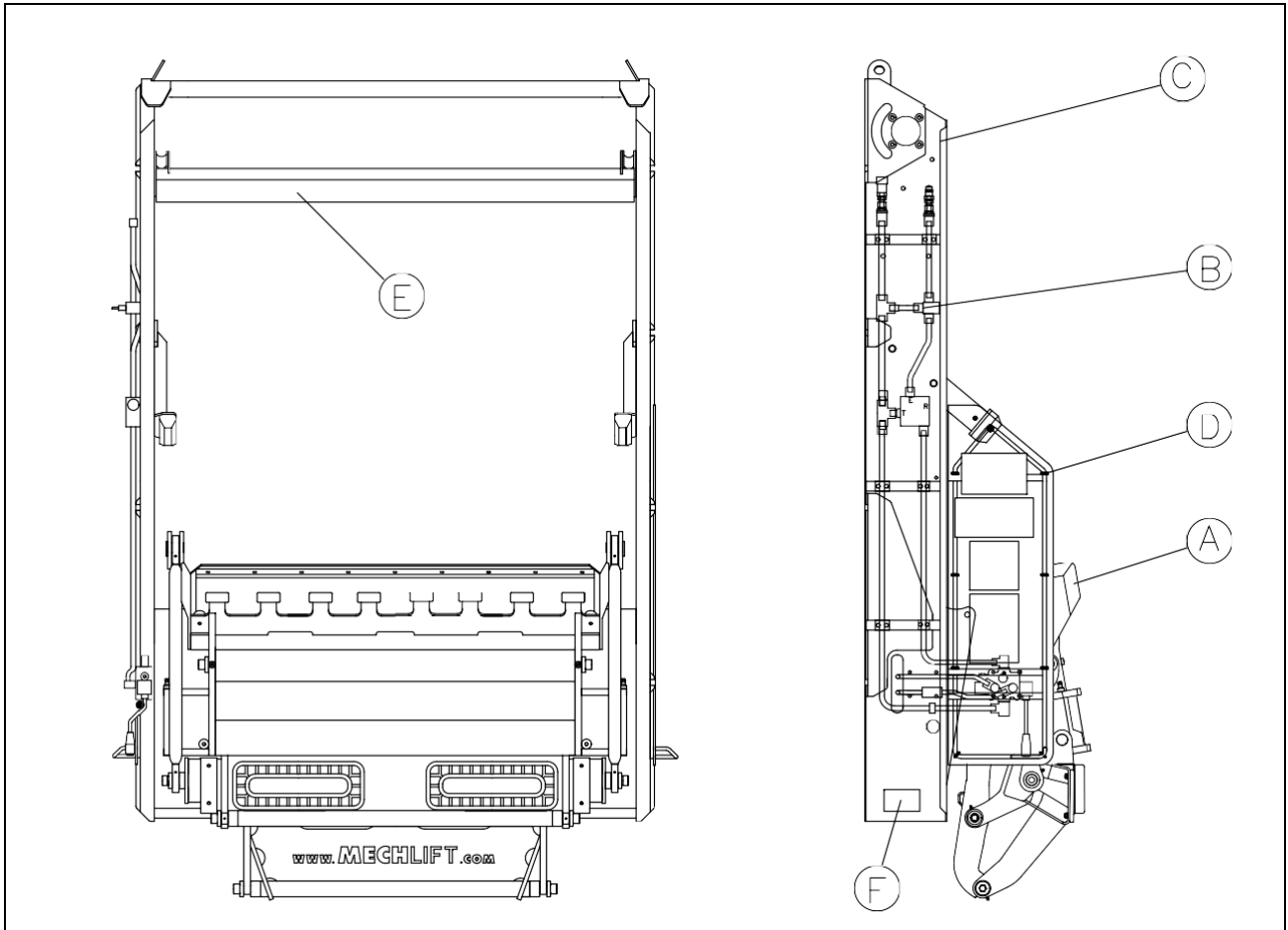

There is a Model ML325TS available as special build for Tshwane. Same as ML325 but with simplified Bin Arrestor - Enquire at Mechlif

SECTION	PART
A	LIFTER ASSEMBLY See page 6 for greater detail
B	HYDRAULIC SYSTEM
C	MAIN FRAME ASSEMBLY
D	GUARD FRAMES - LH & RH
E	STOPPER BAR for bins of 240lit, 360 lit, 660lit and 700 litre maximum
F	SERIAL AND MODEL NUMBERS are here. (lower left side of lifter)

ML 325K BIN LIFTER ASSEMBLY

Part Number: 35 00 101 A

THE ML325K HAS A SPRUNG LID OPENER AND FOLDING LIFTING ARMS FOR 1100litre BINS ON SPIGOTS

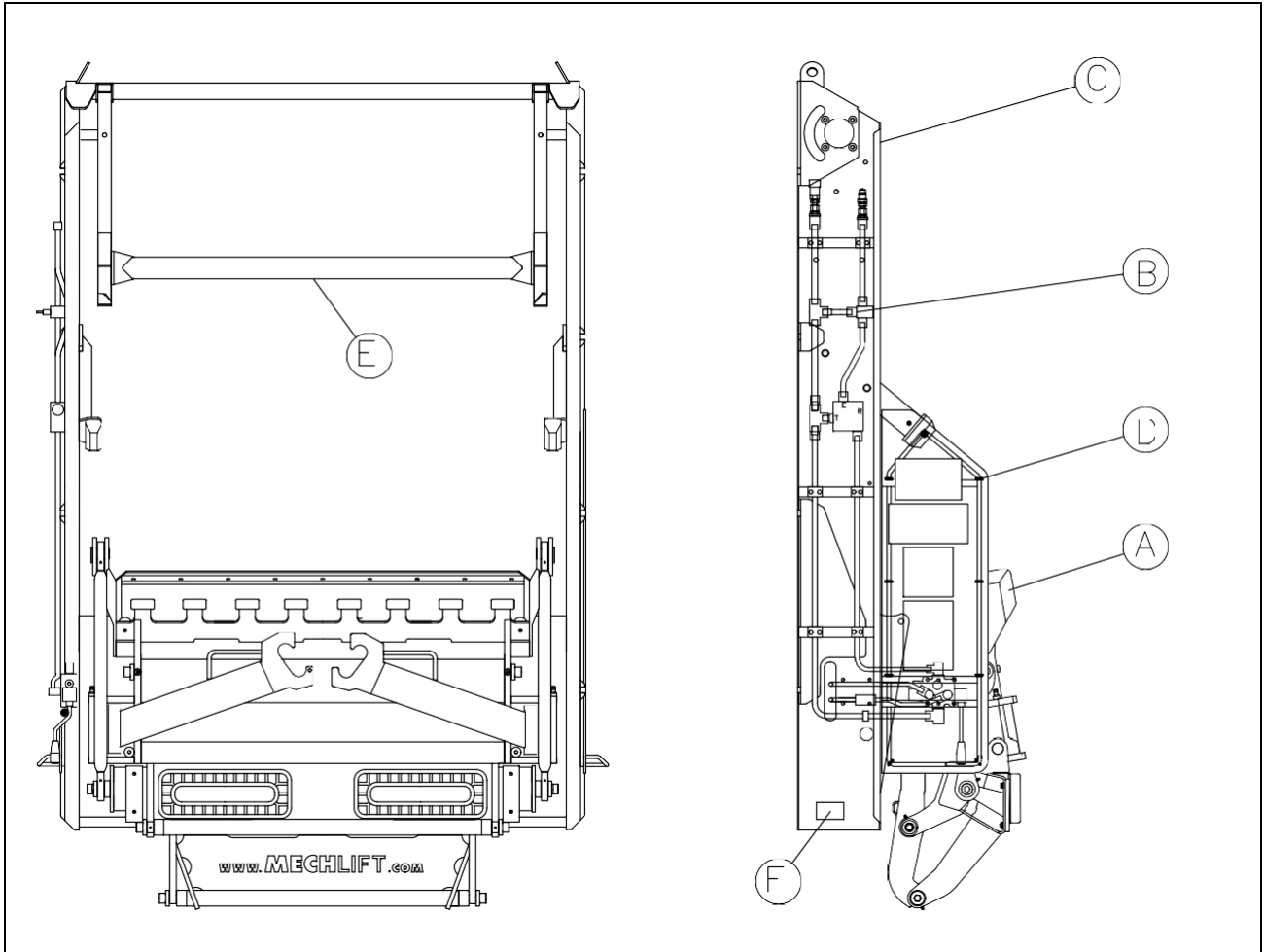

SECTION	PART
A	LIFTER ASSEMBLY See page 6 for greater detail
B	HYDRAULIC SYSTEM
C	MAIN FRAME ASSEMBLY
D	GUARD FRAMES - LH & RH
E	BIN CATCHER / LID OPENER for bins up to 1100litre on spigots. For 1100litre bins on comb lifts, BIN OPENER PULL BACK KIT must be fitted. See elsewhere in this book
F	SERIAL AND MODEL NUMBERS are here. (lower left side of lifter) OPTIONAL EXTRAS

LIFTER SUB ASSEMBLIES

QUICK REFERENCE

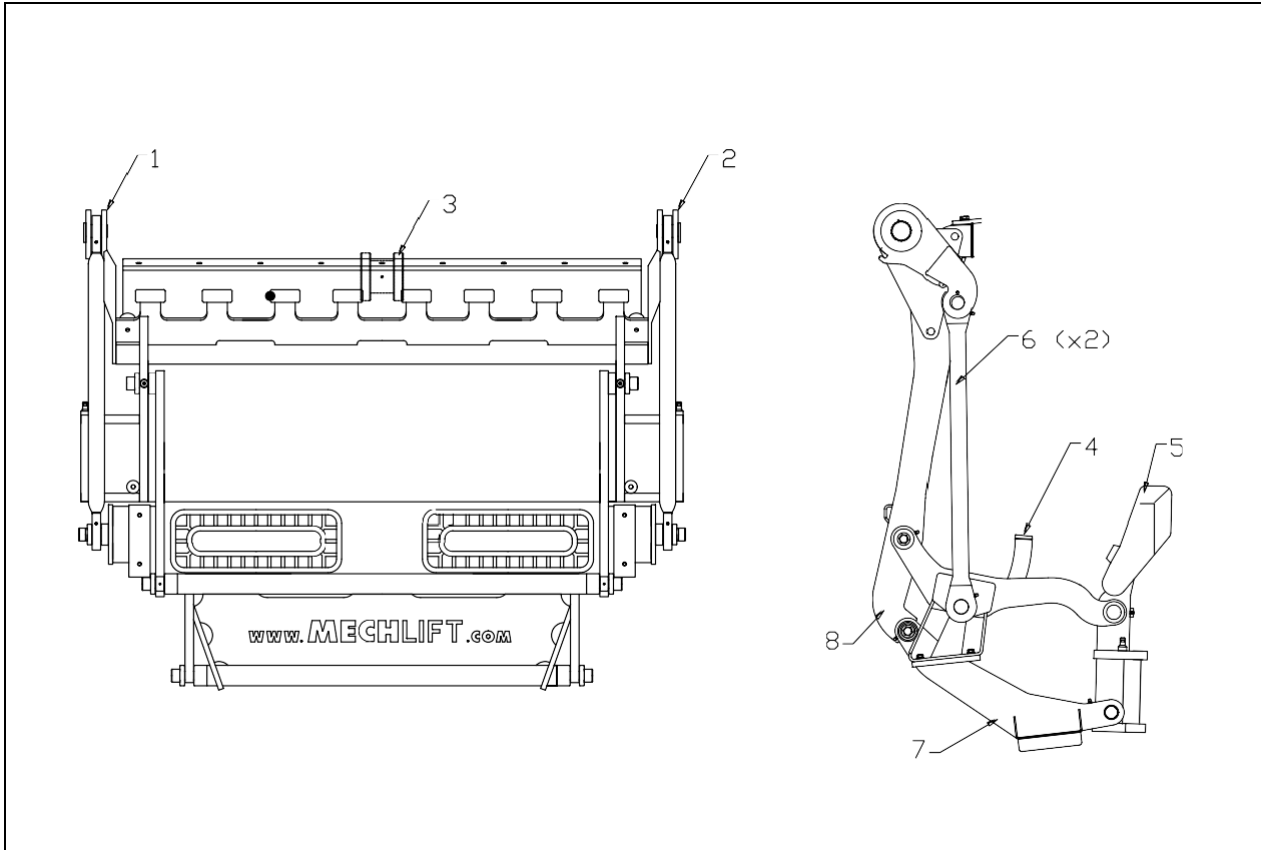

This page tells you what the above parts are called and on what page to find them.

No.	Part No.	Part	
1	35 21 001 A	FULCRUM ARM AND HUB ASSEMBLY - LEFT HAND	Page 8
2	35 21 002 A	FULCRUM ARM AND HUB ASSEMBLY - RIGHT HAND	Page 9
3	35 23 100 A	COUPLING ASSEMBLY (between the two actuator shafts)	Page 10
4	35 40 000 A	H-FRAME ASSEMBLY	Page 11
5	35 50 010 A	COMB FRAME ASSEMBLY (STANDARD)	Page 12
6	35 61 100 A	LONG LINK ROD ASSEMBLY	Page 13
7	35 62 100 A	LOWER LINK FRAME ASSEMBLY	Page 14
8	35 70 000 A	SWING FRAME ASSEMBLY	Page 15

FULCRUM ARM AND HUB ASSEMBLY - *LEFT HAND*

Part Number: 35 20 001 A

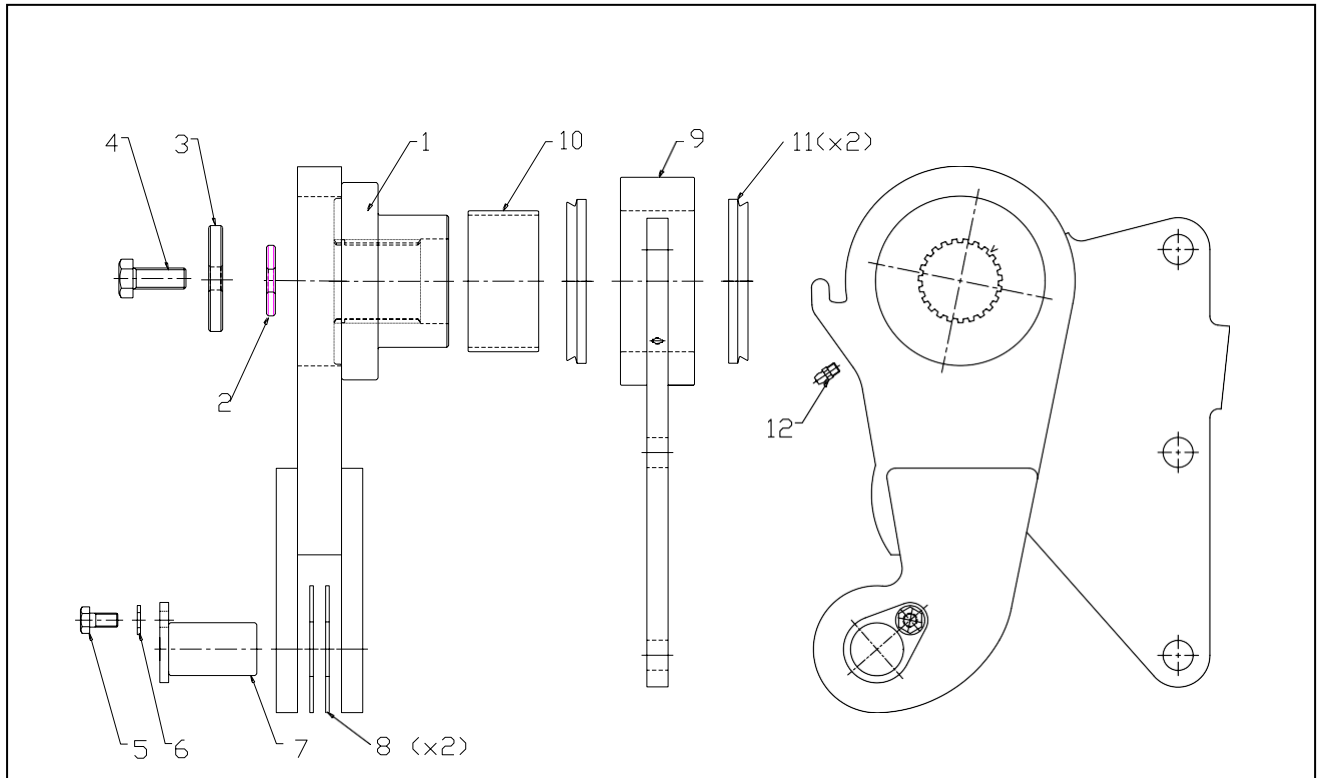

No.	Part No.	Part	Qty per Lifter
	35 20 001 A	FULCRUM ARM & HUB ASSEMBLY LH (complete) Consists of all parts as shown	1
1	35 21 001 A	FULCRUM ARM ASSY LH (incl. item no's 1 to 8)	1
9	35 22 100 A	SWING HUB PLATE ASSY (incl. item no's 9 to 12)	2
kit	07 93 210 K	KIT – Fulcrum arm service (incl. item no's 2 to 8)	2
kit	07 93 220.K	KIT – Swing hub service (incl. item no's 10 to 12)	2

FULCRUM ARM AND HUB ASSEMBLY - *RIGHT HAND*

Part Number: 35 20 002 A

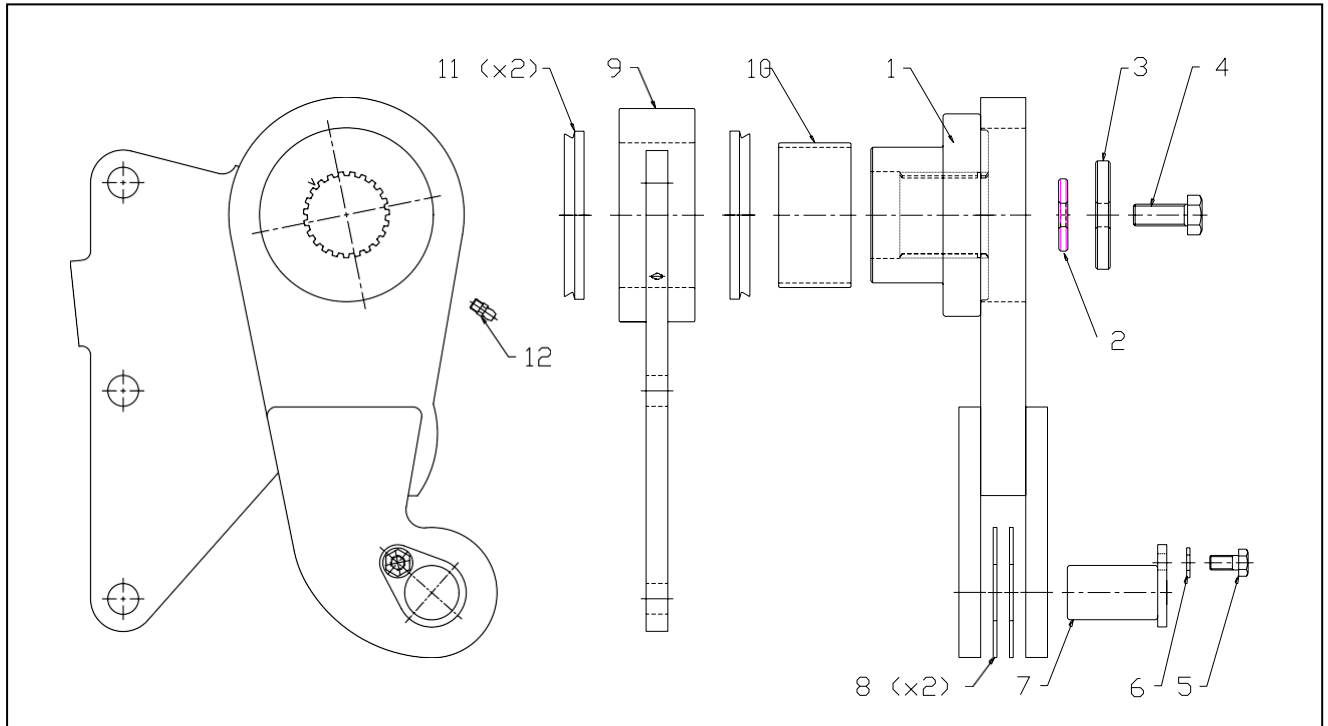

No.	Part No.	Part	Qty Per Lifter
	35 20 002A	FULCRUM ARM & HUB ASSEMBLY RH (complete) Consists of all parts as shown	1
1	35 21 002 A	FULCRUM ARM ASSY RH (incl. item no's 1 to 8)	1
9	35 22 100 A	SWING HUB PLATE ASSY (incl. item no's 9 to 12)	2
kit	07 93 210 K	KIT – Fulcrum arm service (incl. item no's 2 to 8)	2
kit	07 93 220.K	KIT – Swing hub service (incl. item no's 10 to 12)	2

COUPLING ASSEMBLY

Part Number: 35 23 100 A

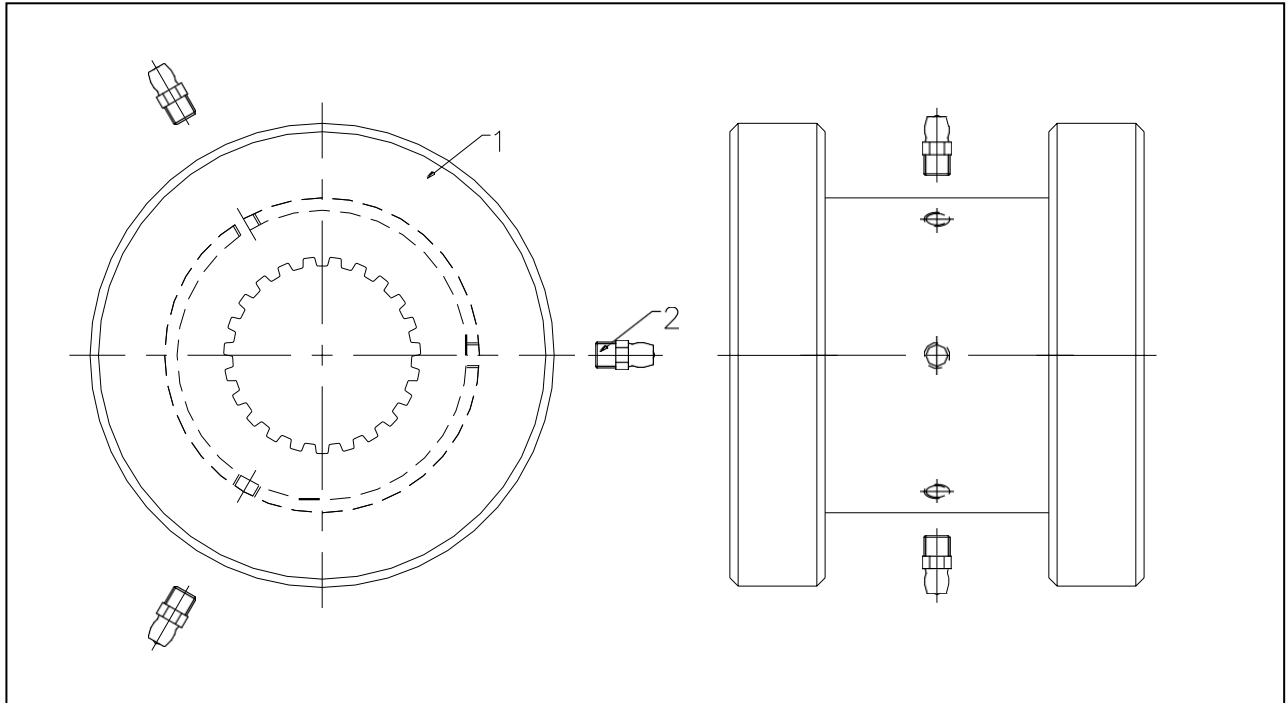

No.	Part No.	Part	Qty per Lifter
	35 23100 A	COUPLING ASSEMBLY LH (complete)	1
1	*NSS	Coupling weldment	1
2	MGN 06	Grease nipple	3

* Not Sold Separately

H-FRAME ASSEMBLY

Part Number: 35 40 000 A

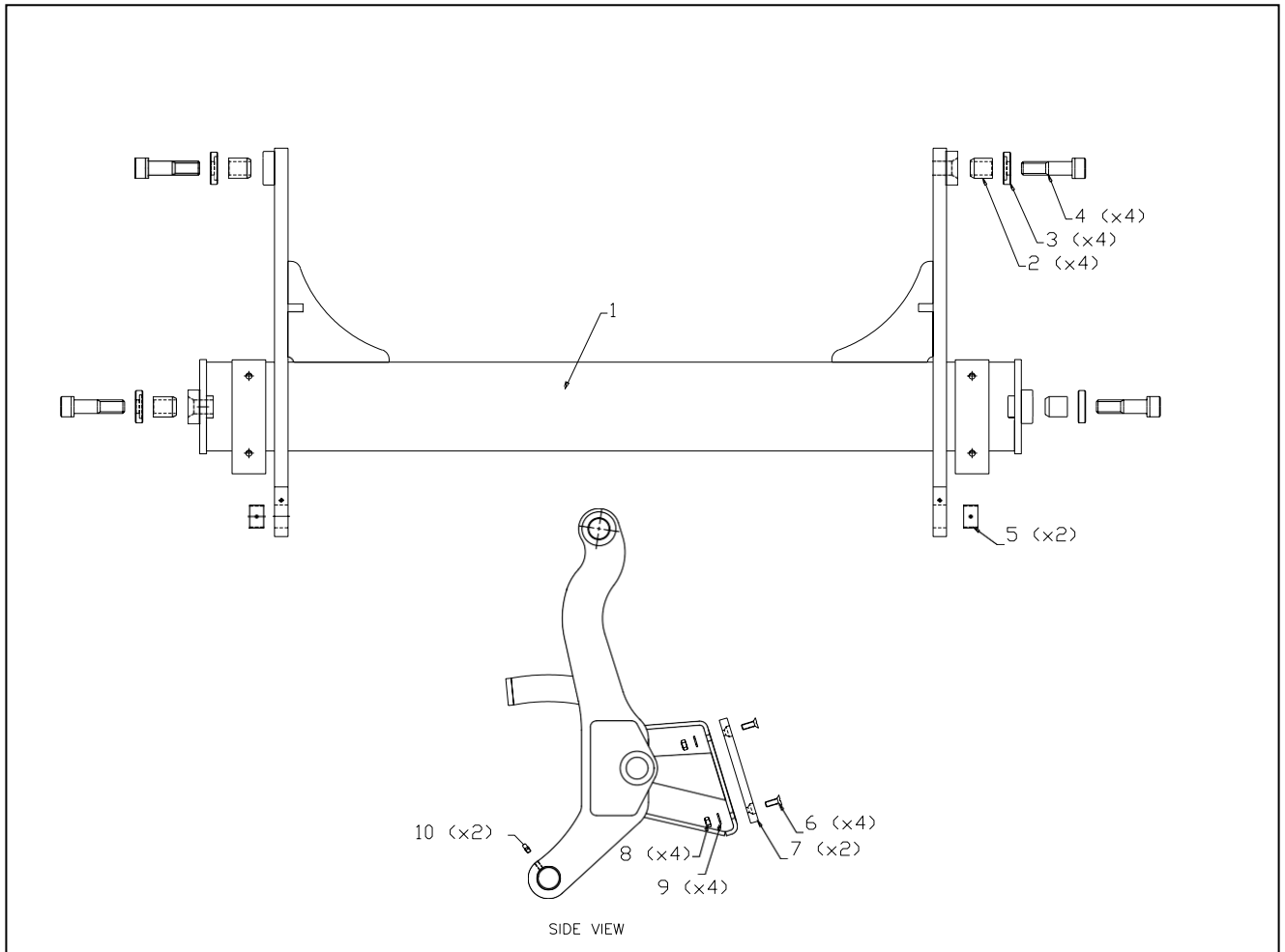

No.	Part No.	Part	Qty per Lifter
	35 40 000 A	H-FRAME ASSEMBLY (complete with all parts shown)	
1	* NSS	H-FRAME WELDMENT	1
kit	07 90 115 K	JOINT SERVICE KIT (incl item no's 2 to 5 and 10)	4
kit	07 93 410 K	KIT – Plastic pad (incl. Item no's 6 - 9)	2
5	BPAP 3020 P20	PERMAGLIDE BUSH	2

* Not Sold Separately

COMB FRAME ASSEMBLY

Part Number: 35 50 010 A

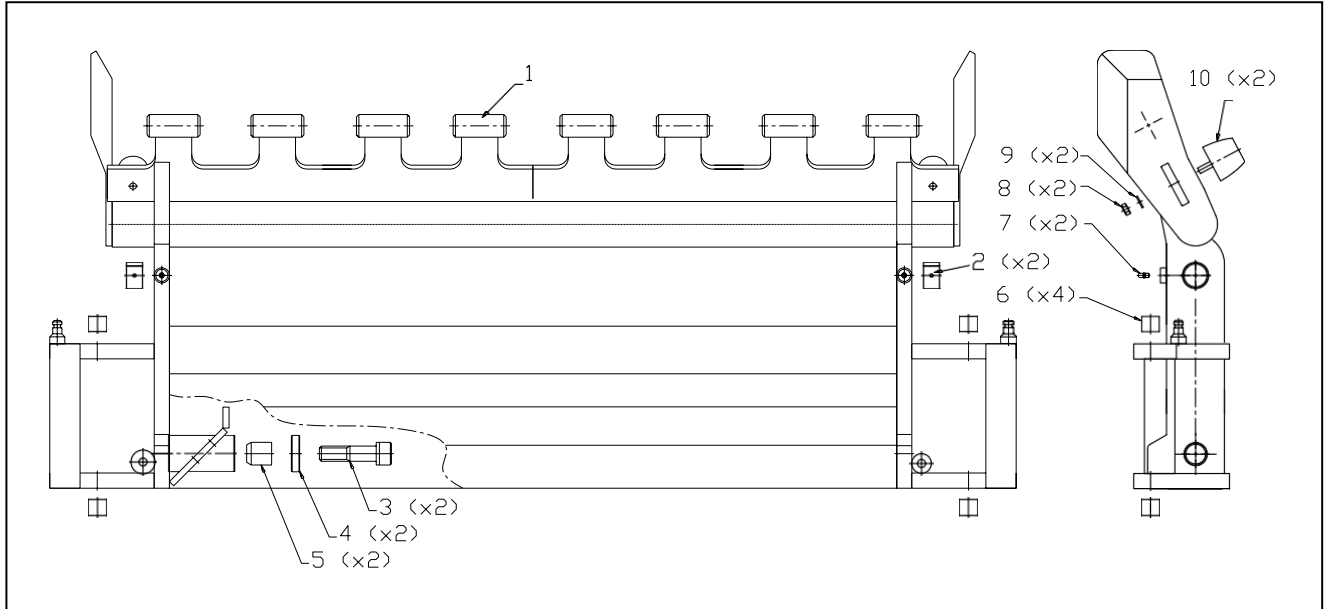

No.	Part No.	Part	Qty per Lifter
	35 50 010 A	COMB FRAME ASSEMBLY (complete – no klaparms)	1
1	* NSS	COMB FRAME WELDMENT	1
10	05 10 132 K	KIT – Conical bump rubber (Incl. item no's 8 to 10)	2
kit	07 90 115 K	JOINT SERVICE KIT (Incl item no's 2 to 5)	2
		Refer to Klaparm section for its 20mm bushes	
6	BPAP 3020 P20	PERMAGLIDE BUSH	2

* Not Sold Separately

LONG LINK ROD ASSEMBLY

Part Number: 35 61 100 A

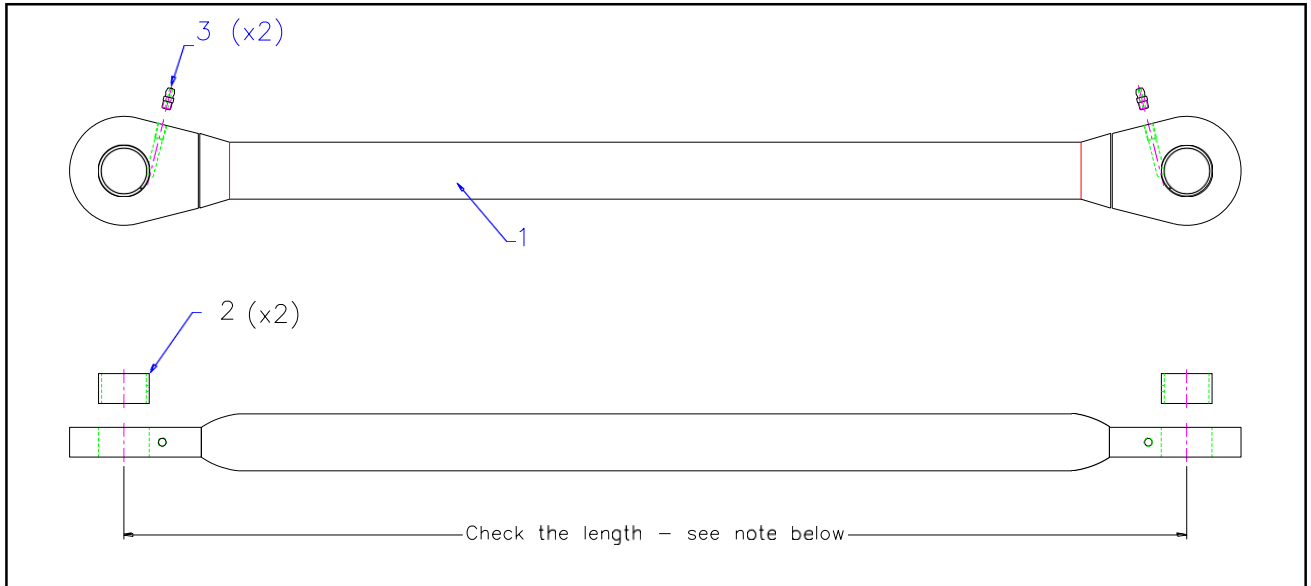

No.	Part No.	Part	Qty per Lifter
	35 61 100 A	LONG LINK ROD ASSEMBLY (complete)	2
1	* NSS	LONG LINK ROD WELDMENT	2
2	BPAP 3020 P20	PERMAGLIDE BUSH	4
3	MGN 08	GREASE NIPPLE M8	4

* Not Sold Separately

NOTE: The length of this link rod was revised late in 2006. Please call us at 021 386 0404 to determine the correct replacement parts.

LOWER LINK FRAME ASSEMBLY

Part Number 35 62 100 A

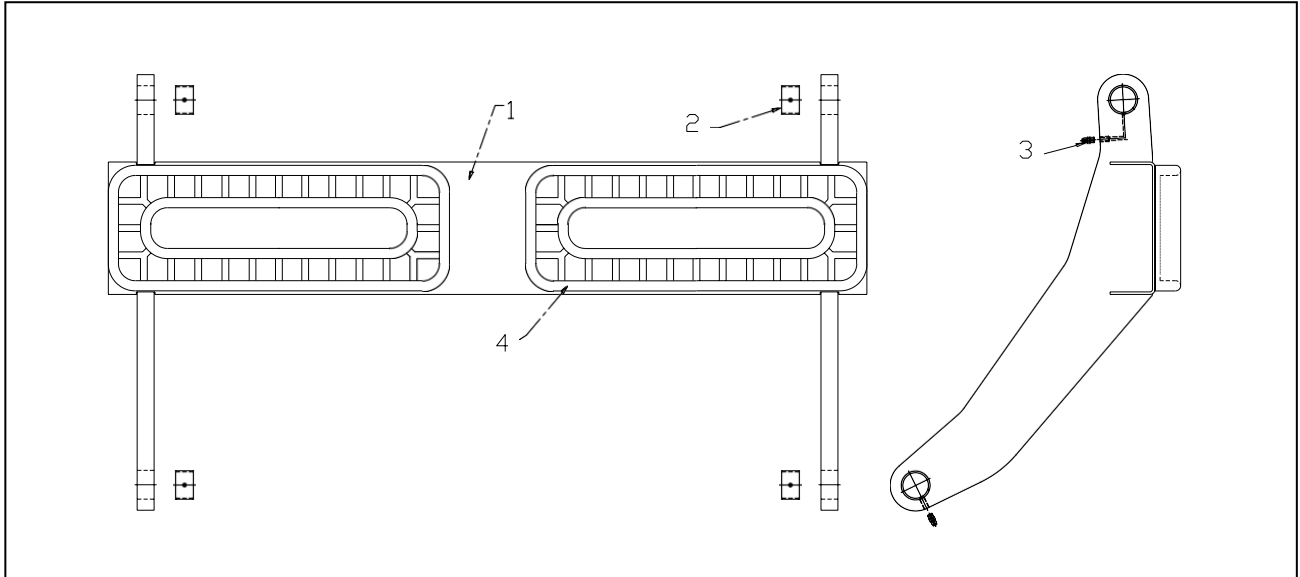

No.	Part No.	Part	Qty per Lifter
	35 62 100 A	LOWER LINK FRAME ASSEMBLY (complete)	1
1	* NSS	LOWER LINK FRAME WELDMENT	1
2	BPAP 3020 P20	PERMAGLIDE BUSH	4
3	MGN 08	GREASE NIPPLE M8	4
4	05.20.105R	RUBBER (Glue on)	2

* Not Sold Separately

SWING FRAME

Part Number: 35 70 000 A

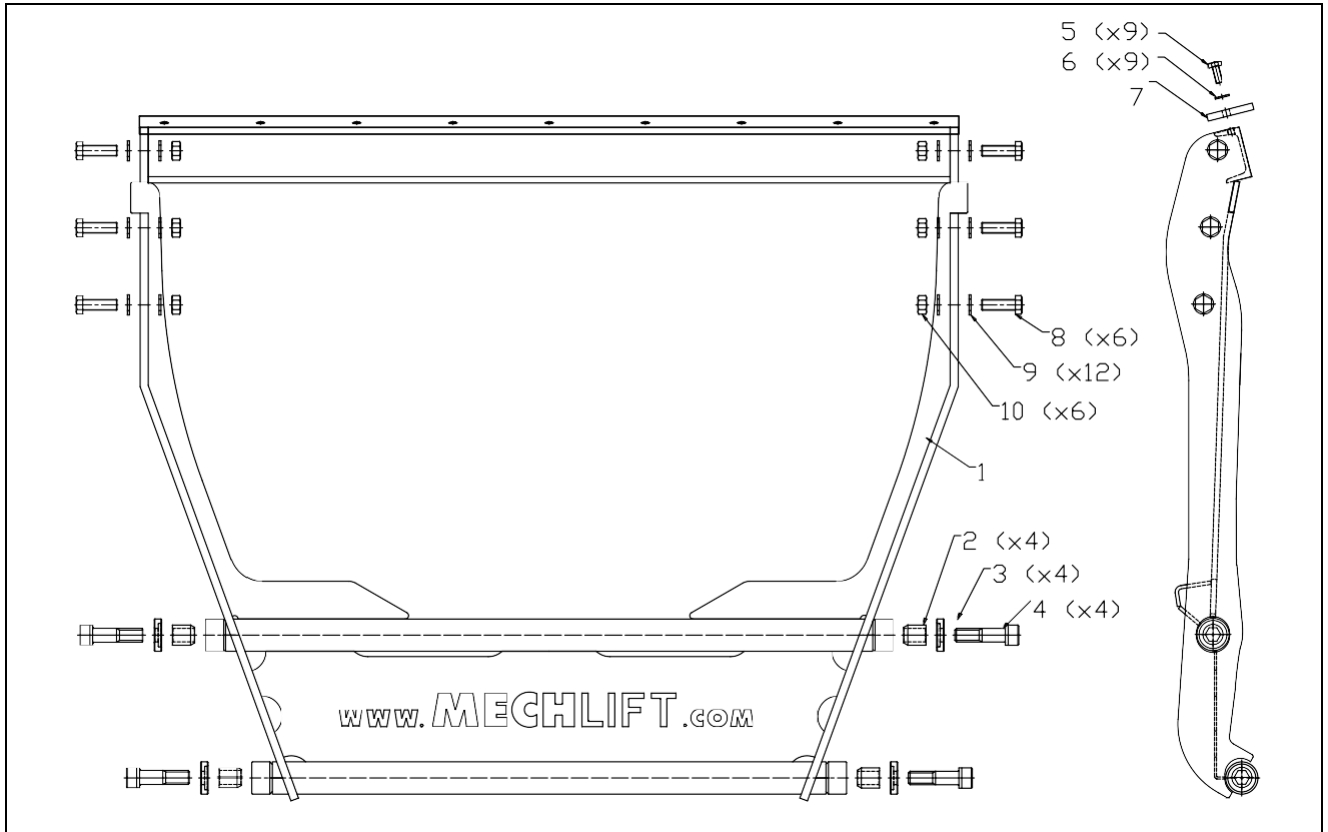

No.	Part No.	Part	Qty per Lifter
	35 70 000 A	SWING FRAME ASSEMBLY (complete)	1
1	* NSS	SWING FRAME WELDMENT	1
kit	07 90 115 K	JOINT SERVICE KIT (incl item no's 2 to 4 & 30mm bush)	4
kit	07 90 116 K	KIT – Bolt and Nut (50mm x 6off)	1

* Not Sold Separately

MAIN FRAME ASSEMBLY

Part Number: 35 90 000 A

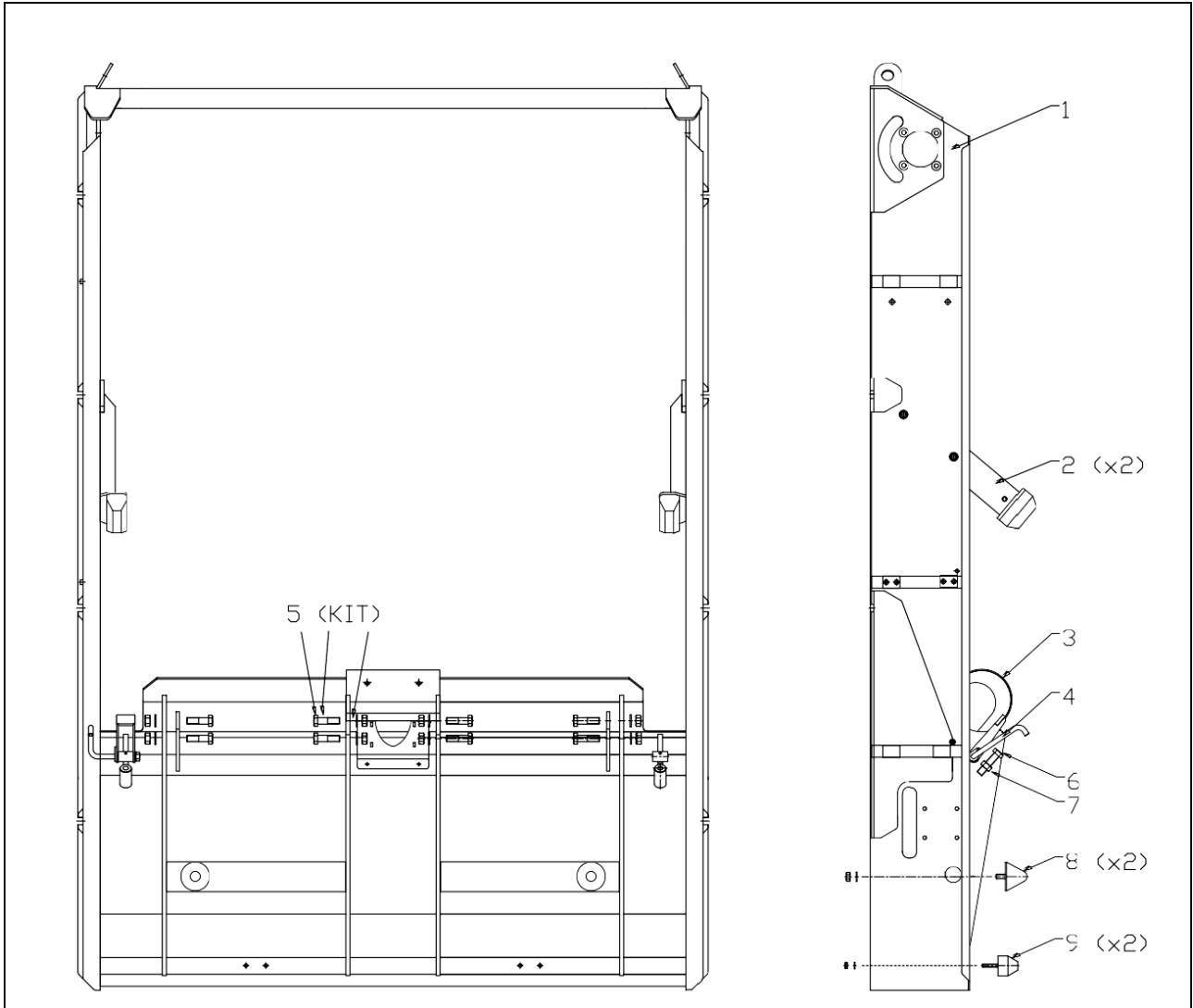

FRAME CONTINUED

No.	Part No.	Part	Qty per Frame
1	35 90 000 A	FRAME ASSEMBLY (incl all items listed below)	1
2	35 92 200 A	UPPER STOP BRACKET ASSEMBLY	2
3	35 23 200 A	COUPLING RETAINER ASSEMBLY	1
4	35 94 300 A	FULCRUM LOCK ASSEMBLY	1
5	07 90 117 K	KIT – actuator fasteners	2
6	FB 1665 H8ZP	STOP BOLT M16 x 65mm	2
7	FN 16 ZP	NUT	2
8	05 10 124 R	RUBBER BUFFER CONICAL 55mm (M12x24)	2
9	05 10 319 R	RUBBER BUFFER RECTANGULAR 100x50 (M8)	2

UPPER STOP BRACKET

Part Number: 35 92 200 A

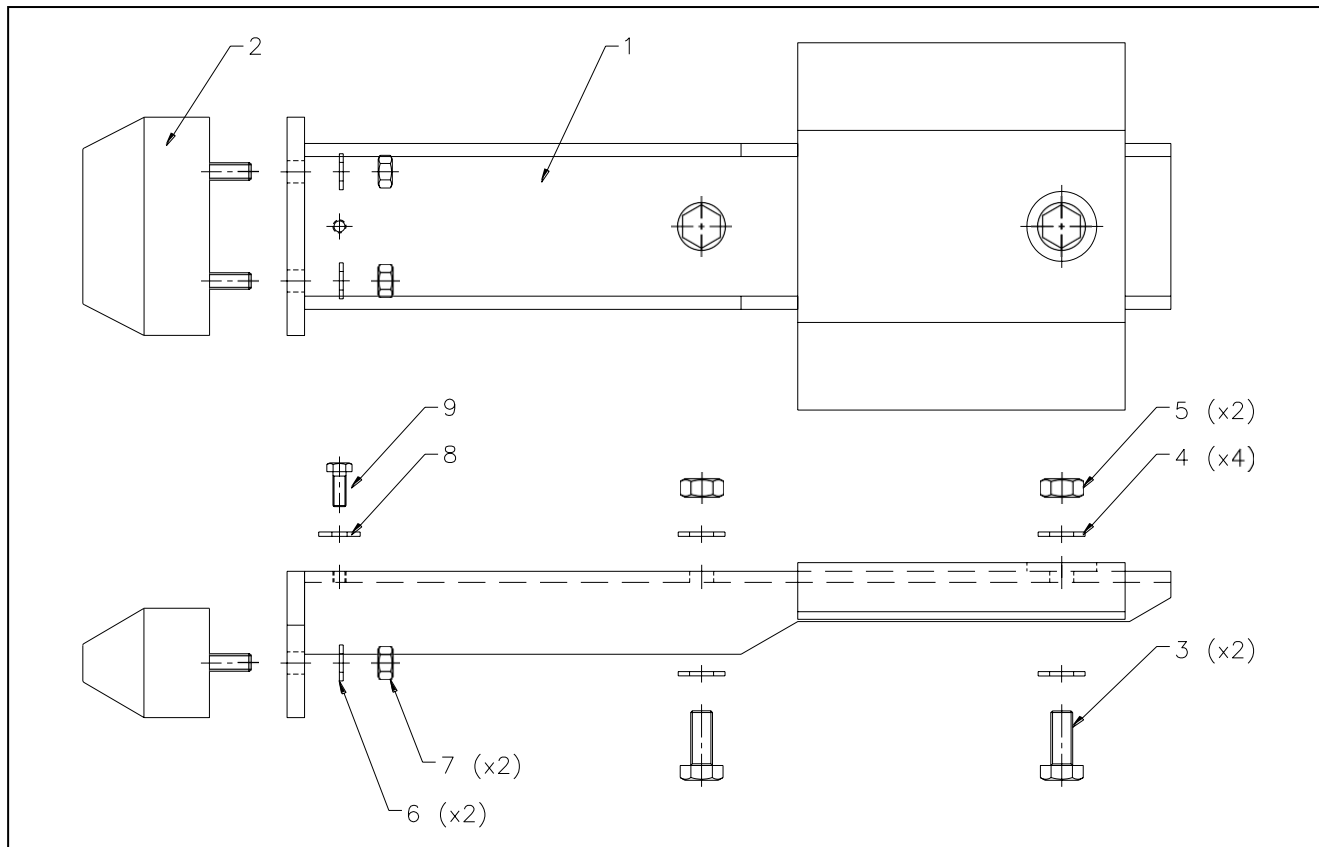

No.	Part No.	Part	Qty per Frame
	35 92 200 A	UPPER STOP BRACKET (complete)	2
1	* NSS	UPPER STOP BRACKET WELDMENT	2
2	05 10 319 R	RUBBER BUFFER RECTANGULAR 100x50 (M8)	2
3	FS1025H8ZP	SCREW M10x25	4
4	FW 10	WASHER M10	8
5	FN10 ZP	NUT M10	4
6	FW 08	WASHER M8	4
7	FN 08 ZP	NUT M8	4
8	FWF 6319020	WASHER (1/4"ID x19mm OD x2mm)	2
9	FS 0616 H8ZP	SCREW M6 x16	2

* Not Sold Separately

COUPLING RETAINER ASSEMBLY

Part Number: 35 23 200 A

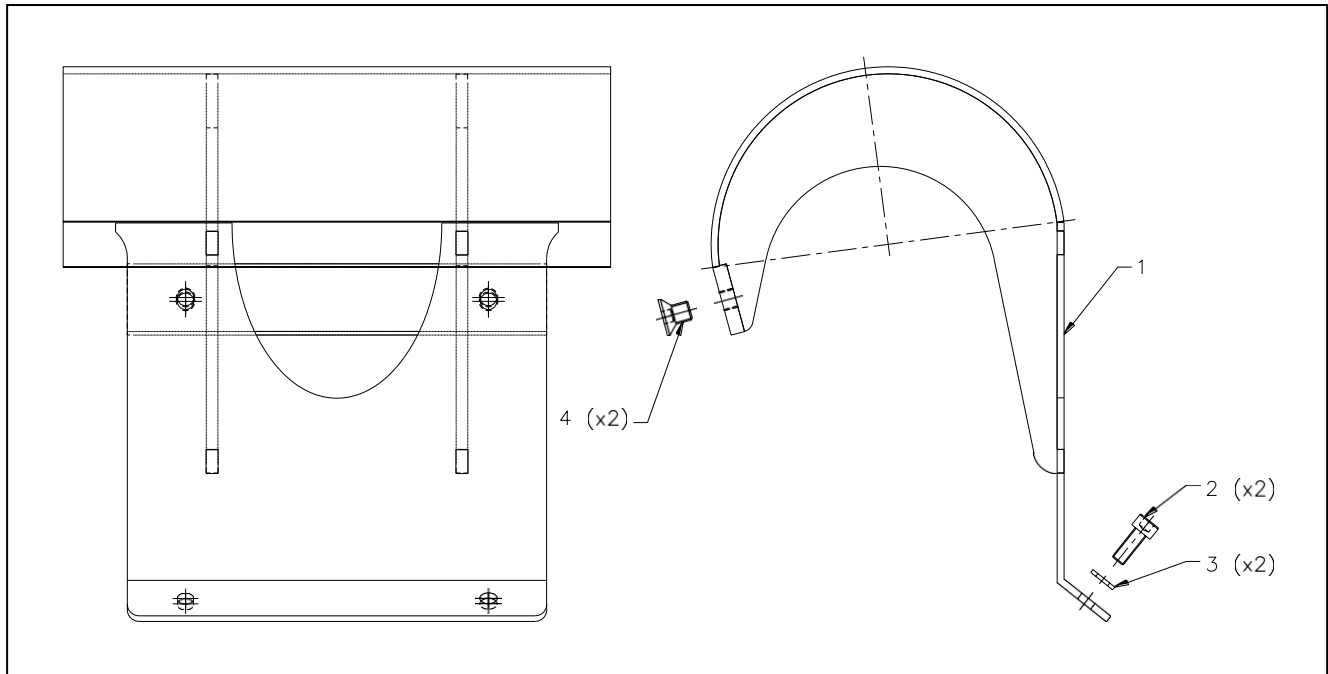

No.	Part No.	Part	Qty per Frame
	35 23 200 A	COUPLING RETAINING ASSEMBLY (complete as shown)	1
1	* NSS	COUPLING RETAINER WELDMENT	1
2	FS 0616 AB	SCREW ALLEN CAP M6 x16 (BLACK)	2
3	FW 08	WASHER M8	2
4	FSCSK 0812 AB	SCREW CSK CAP SCREW M8 x12 (BLACK)	2

* Not Sold Separately

FULCRUM LOCK ASSEMBLY

Part Number: 35 94 300 A

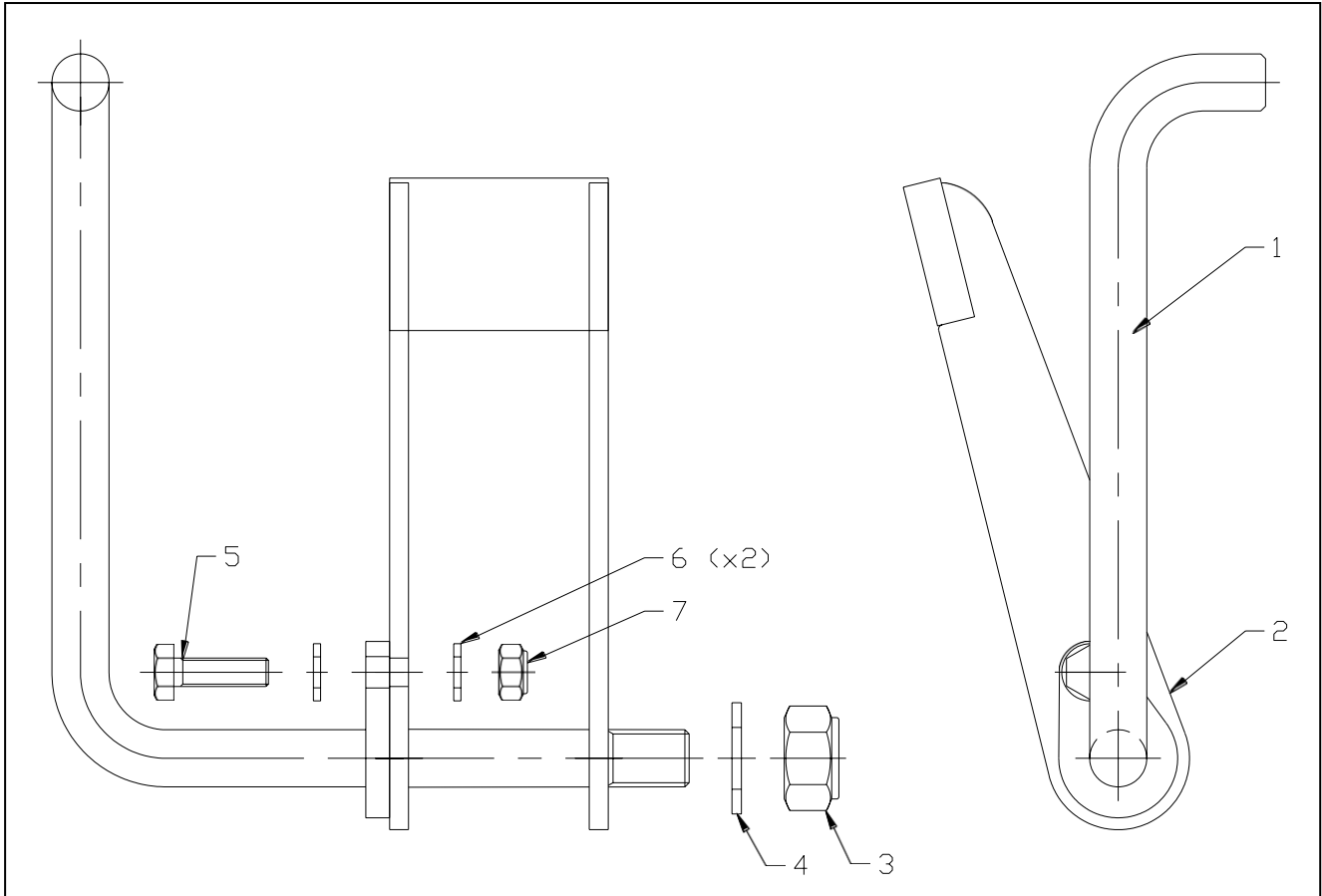

No.	Part No.	Part	Qty per Frame
	35 94 300 A	FULCRUM LOCK ASSEMBLY (complete)	1
1	35 94 310 W	HANDLE WELDMENT	1
2	35 94 300 W	LOCK WELDMENT	1
3	FN 12 NL	NUT NYLOC M12	1
4	FW 12	WASHER M12	1
5	FS 0620 H8ZP	SCREW M6 x20	1
6	FW 06	WASHER M6	1
7	FN 06 NL	NUT NYLOC M6	1

GUARD FRAME ASSEMBLY - LH

Part Number: 01 15 101 A

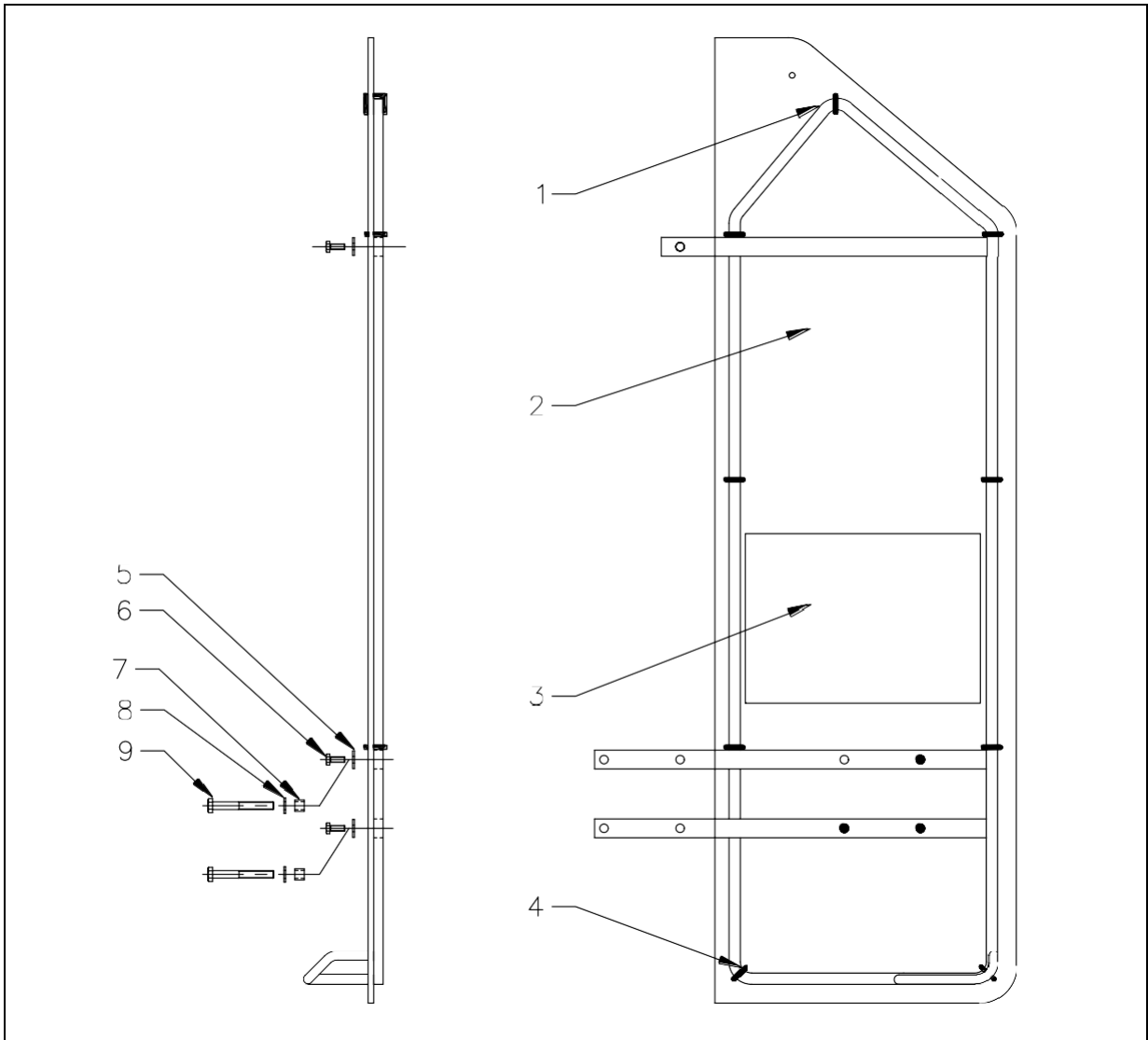

No.	Part No.	Part	Qty per Frame
	01 15 101 A	GUARD FRAME ASSEMBLY – LH (complete)	1
1	01 15 121 E	GUARD FRAME – LH (Metal frame only)	1
2	06 20 111 R	SCREEN (including decal) LH	1
3	09 10 135 X	DECAL	1
4	FTS 05200	TIE STRAP NYLON 5 x200mm	1
5	FW 06	WASHER M6	1
6	FS 0616 H8ZP	SCREW M6 x16	1
7	03 20 212 S	SPACER BUSH	1
8	FW 08	WASHER M8	1
9	FB08065 H8ZP	BOLT M8 x65	1

GUARD FRAME ASSEMBLY - RH

Part Number: 01 15 102 A

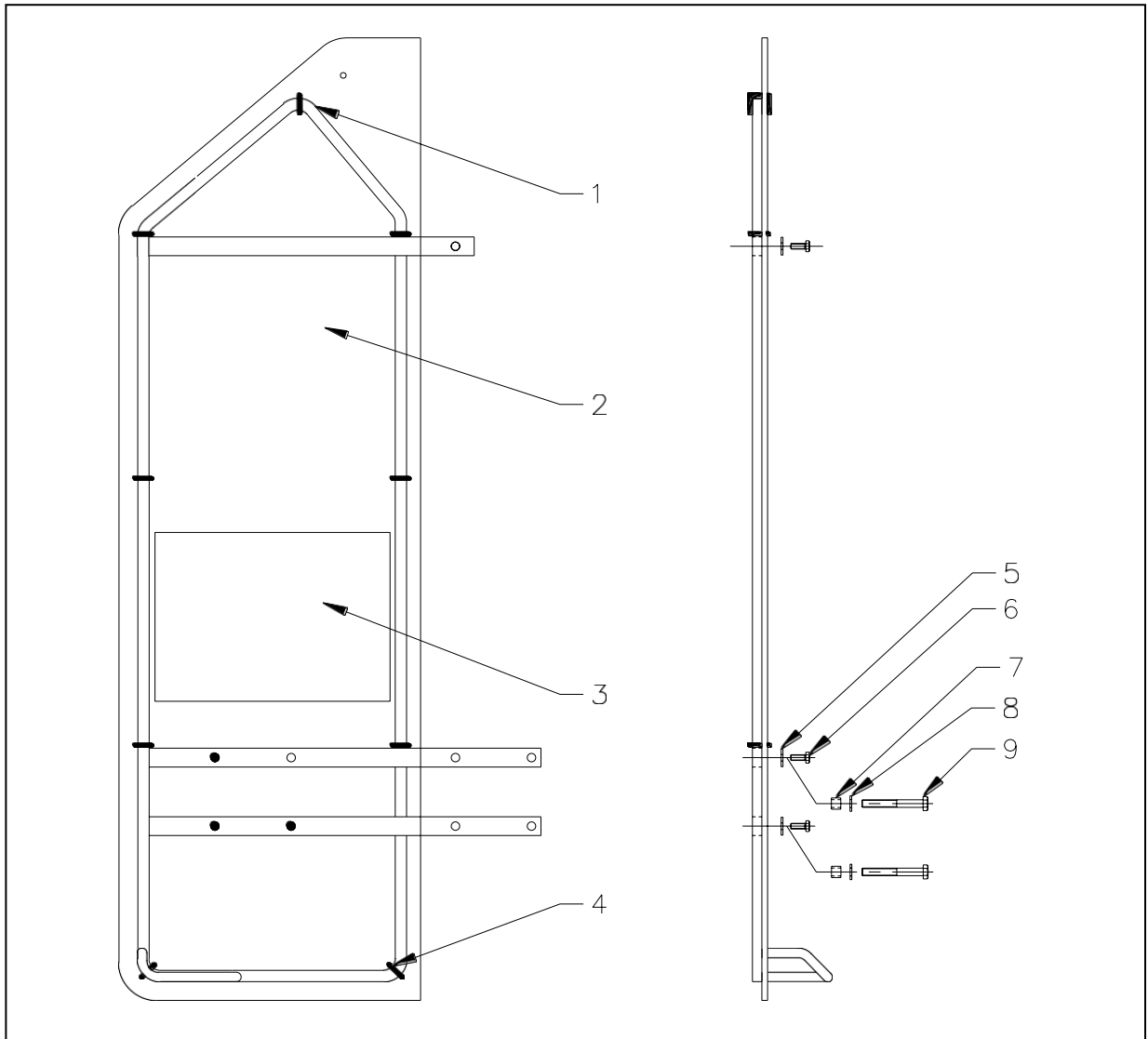

No.	Part No.	Part	Qty per Frame
	01 15 102 A	GUARD FRAME ASSEMBLY – RH (complete)	1
1	01 15 122 E	GUARD FRAME – RH (Metal frame only)	1
2	06 20 112 R	SCREEN (including decal) RH	1
3	09 10 135 X	DECAL	1
4	FTS 05200	TIE STRAP NYLON 5 x200mm	1
5	FW 06	WASHER M6	1
6	FS 0616 H8ZP	SCREW M6 x16	1
7	03 20 212 S	SPACER BUSH	1
8	FW 08	WASHER M8	1
9	FB08065 H8ZP	BOLT M8 x65	1

STOPPER BAR ASSEMBLY

Part Number: 35 92 100 A

USED ON Model ML325 ONLY

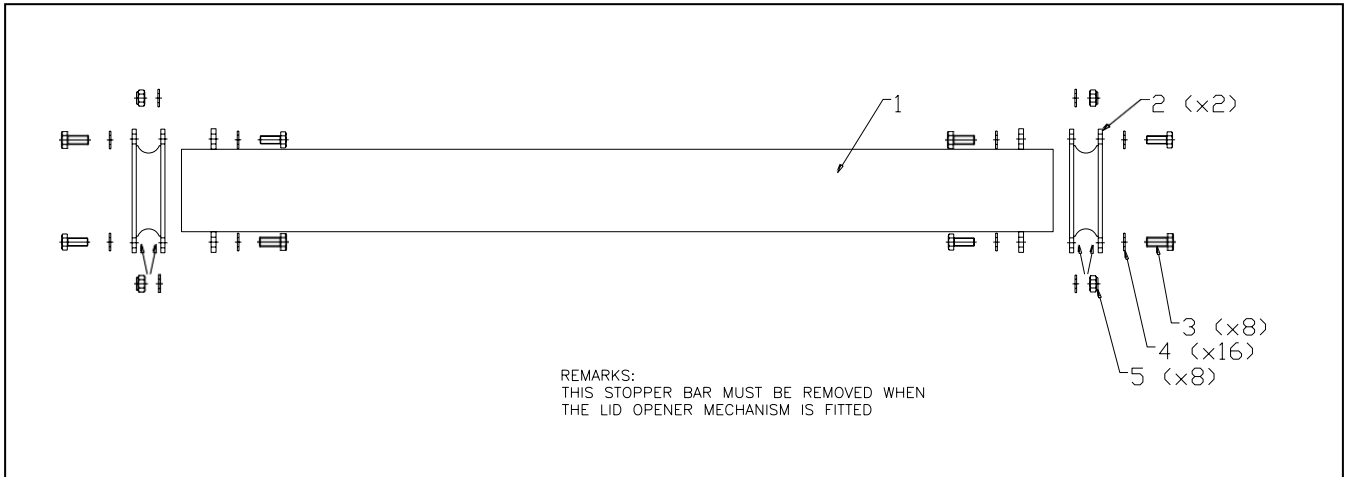

No.	Part No.	Part	Qty perFrame
	35 92 100 A	STOPPER BAR ASSEMBLY (complete)	1
1	*NSS	STOPPER BAR WELDMENT	1
2	35 92 110 R	RUBBER	2
3	FS1025H8ZP	SCREW M10x25	8
4	FW 10	WASHER M10	16
5	FN10 NL	NUT NYLOC M10	8

* Not Sold Separately

LID OPENER ASSEMBLY

Part Number: 35 93 001 A

USED ON Model ML325K & ML325RK ONLY

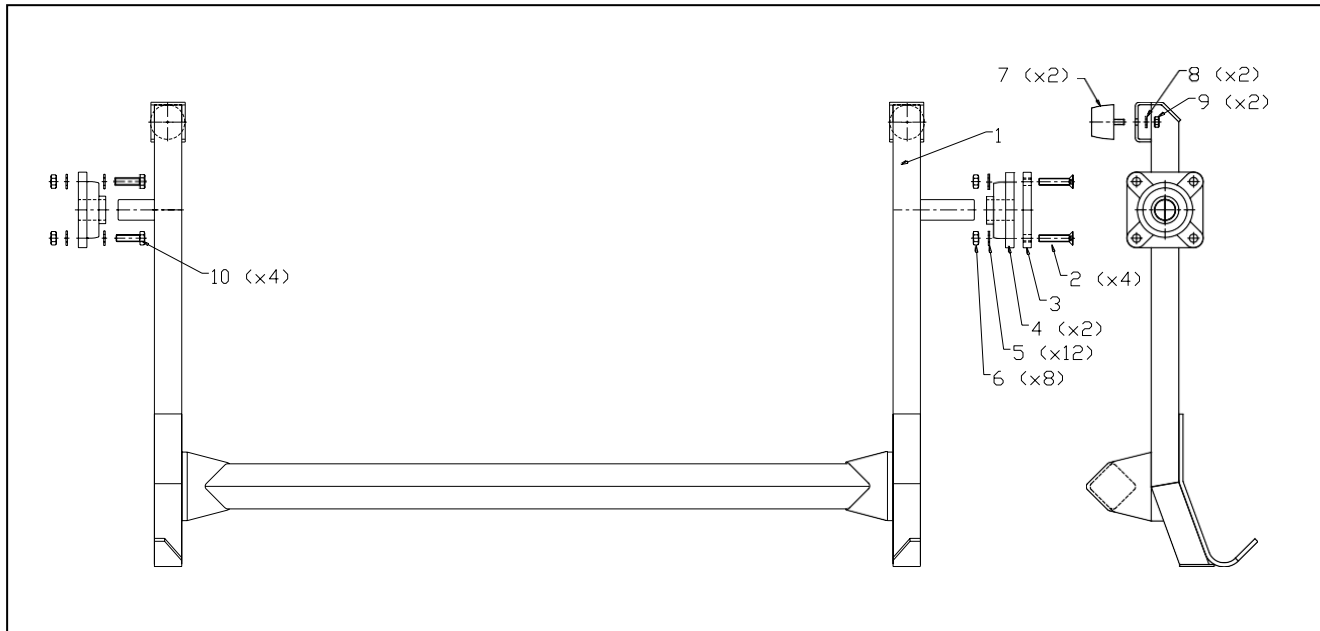

No.	Part No.	Part	Qty per Frame
	35 93 001 A	LID OPENER FRAME ASSY – Complete as shown Excluded is its Control Mechanism – See next page	1
1	35 93 100 W	LID OPENER FRAME WELDMENT	1
2	FSCSK 1050 AB	SCREW CSK CAPSCREW M10 x50	4
3	35 93 205 P	BEARING SPACER	1
4	BUCF 206	FLANGE MOUNT BEARING	2
5	FW 10	WASHER M10	8
6	FN 10 ZP	NUT M10	8
7	05 10 132 K	KIT – Rubber buffer	2
10	FS 1035 H8ZP	SCREW M10 x35	4

* Not Sold Separately

Available is an optional retro fit kit comprising of Lid Opener, Control Mechanism and Pull Back Kit Part No 35 90 002 A = R 13,359.00 which replaces Stopper Bar Assy on page 23

The Model ML325TS is fitted with a simpler version acting as a Bin Arrestor than is shown here. Enquire at Mechlift when spares are required.

Lid Opener CONTROL MECHANISM

Part Number: 35 93 200 A

USED ON Model ML325K, ML325RK & ML325TS ONLY

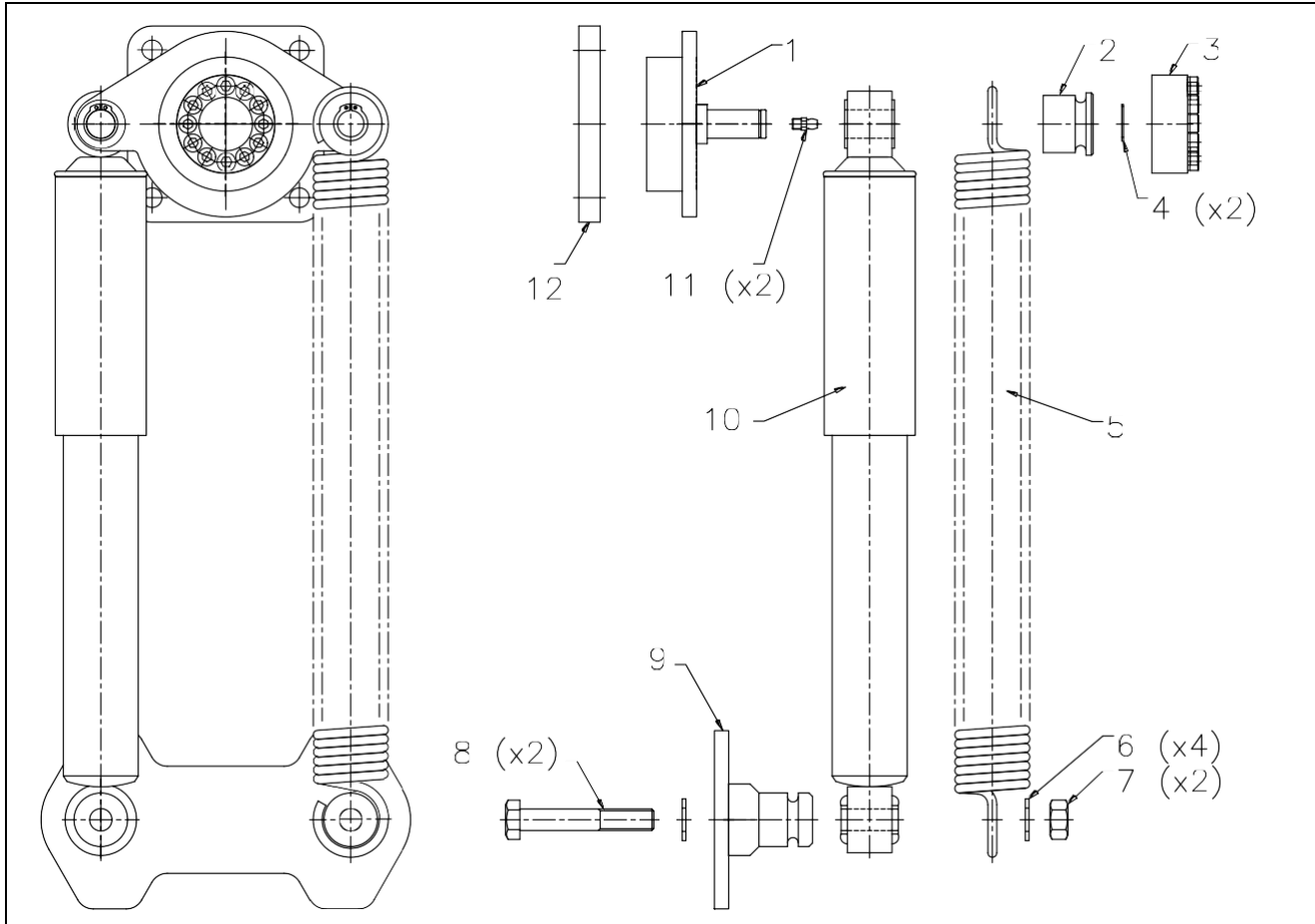

No.	Part No.	Part	Qty per Frame
	35 93 200 A	LID OPENER CONTROL MECHANISM - COMPLETE	1
1	35 93 210 W	BELLCRANK WELDMENT	1
2	06 40 021 T	BUSH	1
3	FCONEX 30	QUANTUM 30 30x55	1
4	FC 16 E	CIRCLIP DIAMETER 16mm EXTERNAL	2
5	04 10 006 E	SPRING - PLATED	1
6	FW 12	WASHER M12	1
7	FN 12 NL	NUT NYLOC M12	2
8	FB 1275 H8ZP	BOLT M12 x75	2
9	35 93 220 W	MOUNTING PLATE WELDMENT	1
10	35 93 230 D	DAMPER	1
11	MGN 06	GREASE NIPPLE M6	1
12	35 93 205 P	BEARING SPACER	1

* Not Sold Separately

BIN OPENER PULL BACK KIT

Part Number: To be advised

Required for 1100 & 1100litre bins with flat lids on a comb pick up. For these the sprung lid opener must be pulled back, hence this kit.

Consists of a handle, cable and bracketing

No diagram yet - details available from Mechlift

No.	Part No.	Part	Qty per Frame
1	35 93 140 W	HANDLE	1
2	35 90 103 X	Wire Rope 4mm Stainless Steel	1
3	35 90 104 X	Cable clamps 4mm	2
4	35 90 106 X	Thimble 5mm Stainless steel	2
5	35 90 107 X	Shackle 8mm Galv 'D	1

KLAPARM KIT

Part Number: 35 90 003 A

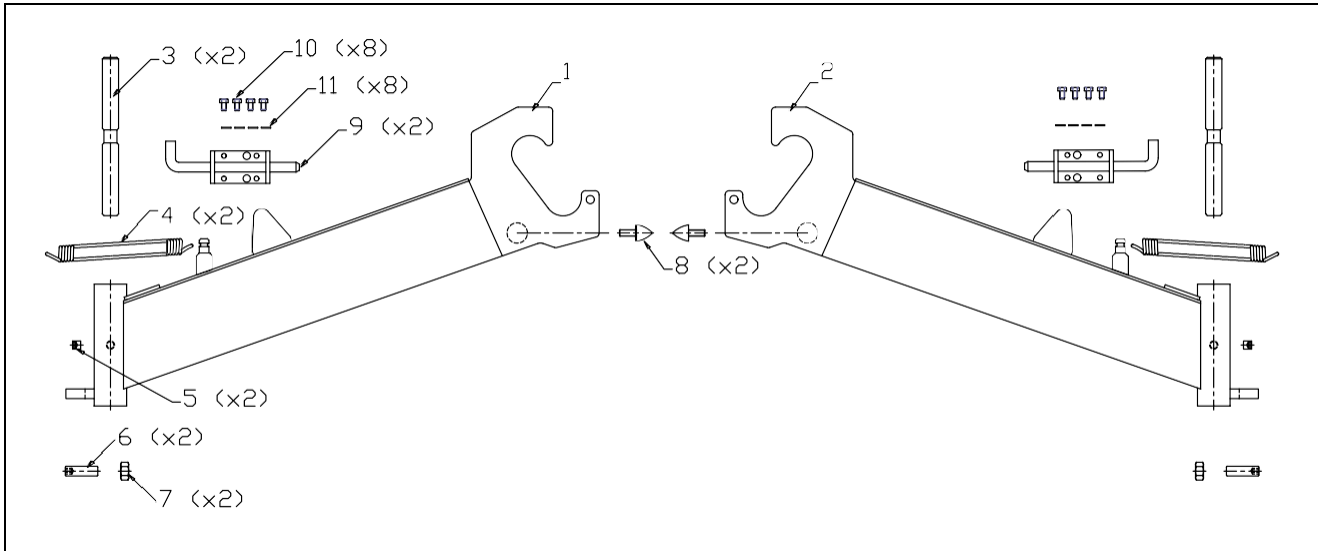

No.	Part No.	Part	Qty per Frame
	35 90 003 A	KLAPARM KIT Complete excl Sliding Bolts	1
1	35 53 101 W	BIN CARRIER ARM - LH	1
2	35 53 102 W	BIN CARRIER ARM - RH	1
3	31 53 010 T	KLAPARM HINGE PIN	2
4	04 10 003 E	SPRING - KLAPARMS	2
5	FSG 1012 ZP	SCREW GRUB M10 x 12	2
6	FSG 1240 ZP	SCREW GRUB M12 x 40	2
7	FN 12 ZP	NUT M12	2
8	MCR 205	RUBBER BUFFER RPM 205	2
9	MSB164	SLIDING BOLT – Spring loaded (1)	2
10	FS 0610 ZP	SCREW M6 x 10	8
11	FW 06	WASHER Ø6	8

* Not Sold Separately

(1) Only required on De-Mount Lifter

HYDRAULIC SYSTEM

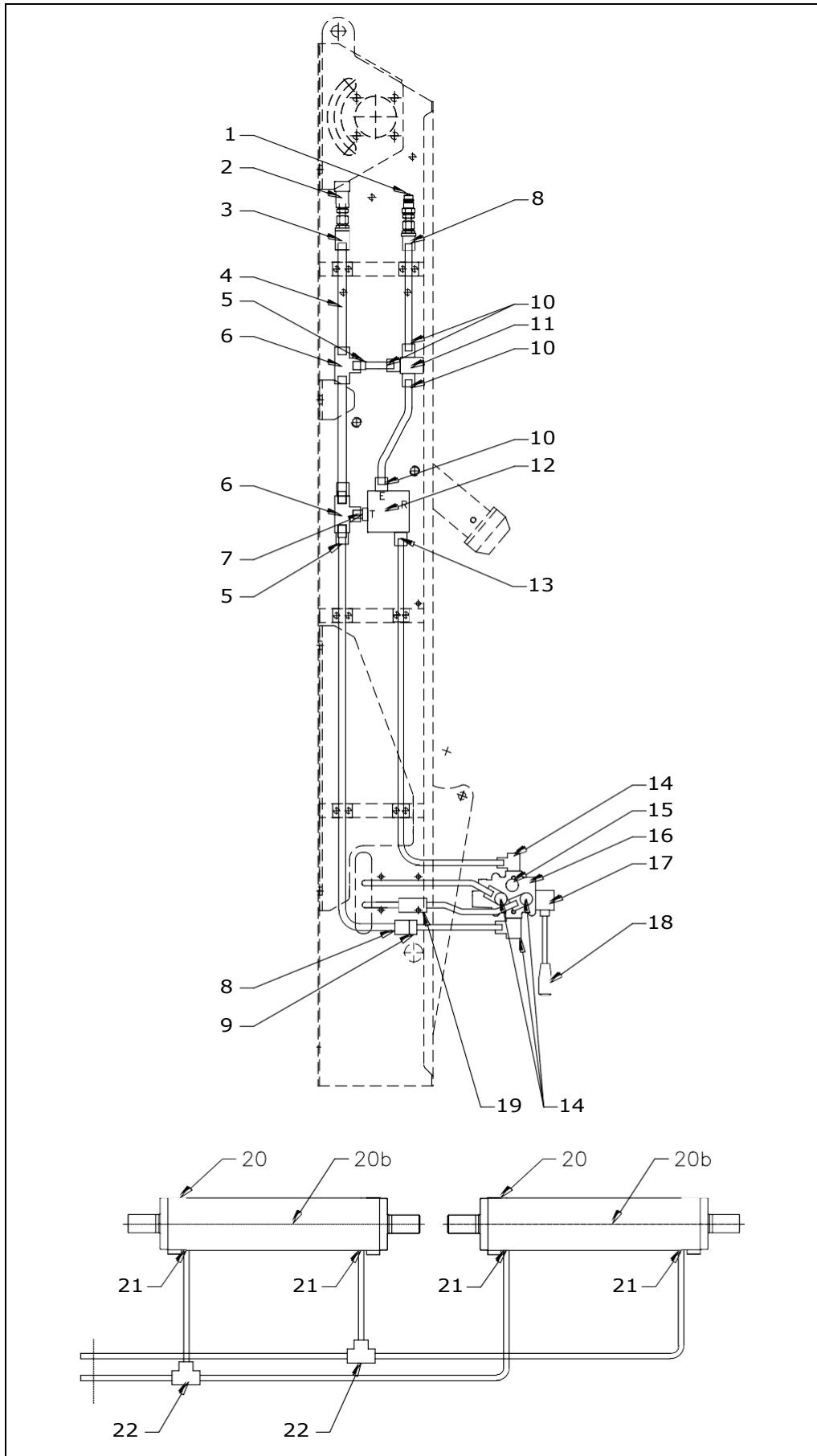

HYDRAULIC SYSTEM CONTINUED

No.	Part No.	Part	Qty per Frame
1	HCM12 5.ISO	MALE QUICK COUPLER ½ "	1
2	HCF12 5.ISO	FEMALE QUICK COUPLER ½ "	1
3	HG.18.L	STRAIGHT COUPLING 18mm	1
4	35 10 000 E	HYDRAULIC PIPE SET	1
4a	35 10 001 SP	INDIVIDUAL PIPE (NON PLATED)	1
5	HRED.18/15.L	REDUCING STANDPIPE	1
6	HT.18.L	TEE COUPLING	1
7	HEVGE.18.LR.ED	STANDPIPE STRAIGHT STUD	1
8	HG.15.L	STRAIGHT COUPLING 15mm	1
9	HRED.15/12.L	REDUCING STANDPIPE	1
10	HGE.15.LR.ED	STRAIGHT MALE STUD FITTING	1
11	HV.MAIN.RELIEVE	MAIN RELIEF VALVE	1
12	HV.FLO.REG 50	FLOW REGULATOR	1
13	HGE.12.PLR.1/2.ED	STRAIGHT MALE STUD ½ TO 12mm	1
14	HWH.12LR	BANJO COUPLING WH.12LR	1
15	HMINI3.8	MINITEST COUPLING – 3/8" BSP -ED	1
16	HV.VCD20.LH	CONTROL VALVE LH (Includes LeverBox but excludes Fittings & Handle)	1
17	HV.VCD.BOX	LEVER BOX ASSEMBLY (shaped square)	1
17b	HV.VCD.CAP	END CAP ASSY (shaped round & spring side)	1
18	01 40 010 R	VALVE HANDLE	1
19	HV.FLO.REST.35	FLOW RESTRICTOR (Drilled 3.5mm)	1
20	08 10 141 X	ACTUATOR	1
20b		SEAL KIT	1
21	03 70 001 T	SPECIAL FITTING – Actuator Port	1
22	HT.12.L	TEE COUPLING	

* Not Sold Separately

ACTUATOR SERVICE PARTS

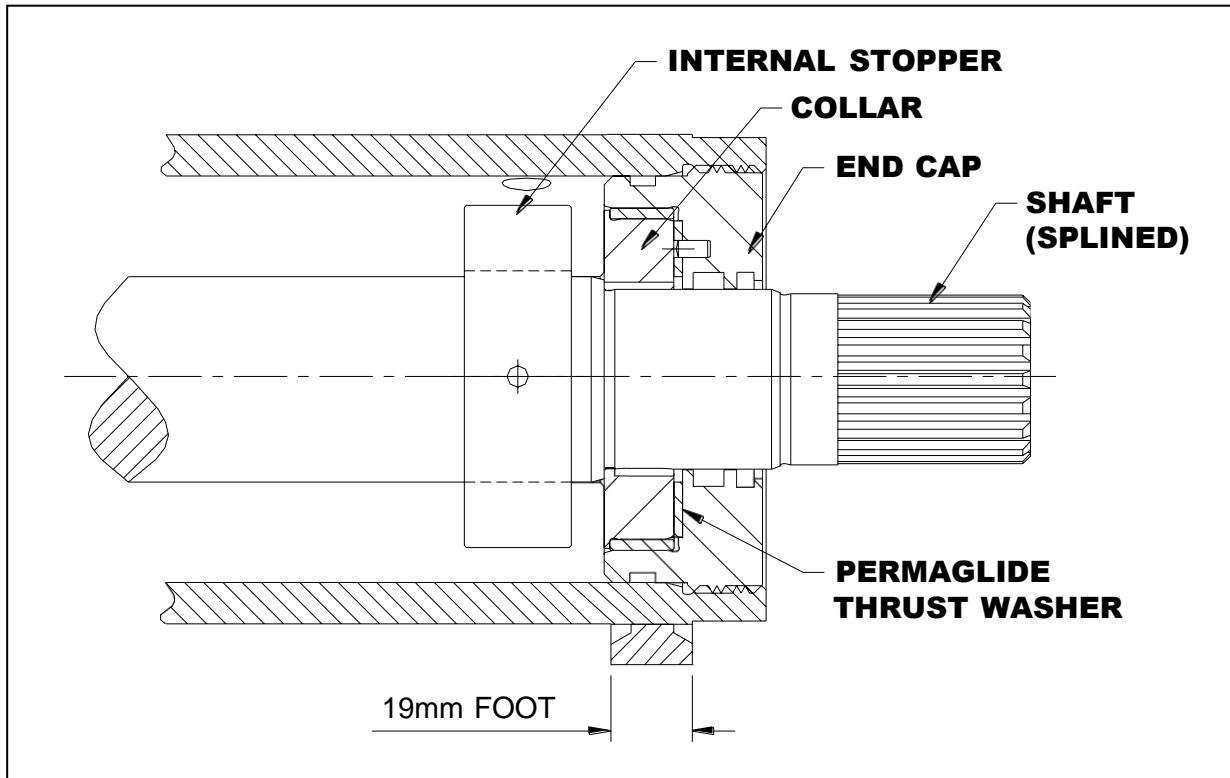

Part No.	Part	Qty per Actuator
08 10 141 X	ACTUATOR	1
A SKH22 000	SEAL & BRG KIT – For full overhaul (Genuine OEM)(includes stopper , thrust washers and seals)	1
A SKH22 300	SEAL KIT – End cap side only (Genuine OEM)(includes wiper, seal, o’ring, backup ring)	2
06 10 241 T	ACTUATOR INTERNAL STOPPER (use only genuine OEM part)	1
A SKH22 002	THRUST WASHER	2
--	SHAFT	1
--	COLLAR (only sold as part of End Cap below)	2
08 10 144 X EC	END CAP Complete with collar, seals, thrust washer	2

NB: Observe internal timing marks **BEFORE** pulling piston and shaft from barrel

Contact information:

Please feel free to contact us should you have any queries or need any further information:

Telephone: +27 (0) 21 386 0404

Fax: +27 (0) 21 385 1886

E-mail:
... General enquiries query@mechlift.com
... **Sales enquiries** sales@mechlift.com

Web address: www.mechlift.com

Physical Address: 84 Mobile Road Airport Industria Cape
Town 7490
South Africa

Postal Address: 84 Mobile Road Airport Industria Cape
Town 7490
South Africa

Please Note:

Some assemblies may require more than one of the same unit, part or kit. Mechlift (Pty) Ltd reserves the right to change prices and /or part numbers without notification. (based on Euro/Pound rate 20:23)

Copyright ©

This publication, or parts thereof, may not be reproduced in any form, by any method, for any purpose, without prior written permission from Mechlift (Pty) Ltd.

Liability

Whilst every attempt has been made to assure the accuracy of this manual, Mechlift (Pty) Ltd cannot accept responsibility for any errors, which may occur.
All information given is subject to change without notice



