

MECHLIFT 805 Bin Lifter



The **ML805** bin lifter was developed to fill the need for a lifter combining the best attributes of both a low and high-level lifter without the negative aspects of these, namely:

-Low-level lifters do not interfere with the handling of bagged refuse, but the compactor cannot run when bins are being tipped

-High level lifters while being able to handle a large volume of bins, do not find favour when large amounts of bagged refuse is handled owing to their height.

Further, high level lifters suffer from poor ground clearance when lowered and are thus susceptible to damage especially when reversing through dips.

The **ML 805** answers these needs by having high ground clearance, a low sill, a high tipping level while being able to handle the two- and four-wheeled plastic bins as well as the steel (Sprico type) bins of 1100 litre. When the combs are split for the smaller two-wheeled bins, cycle times of 8 seconds are achieved with a hydraulic supply rate of less than 30 litres per minute enabling your vehicles to be significantly quieter and more fuel efficient while doing their rounds.



The two sides of the lifter are independently controlled when handling two-wheeled bins. On opening the trunnion arms to handle the larger four-wheeled bins, the two lifter sections are mechanically locked.

As with all Mechlift lifters, the **ML805** uses mostly standard parts, which are readily available from local suppliers.

Mechlift bin lifters have become popular over the years because they are simple, robust and efficient. They all use a reliable rotary actuator for the whole lift and tip cycle, which results in a smooth action with low hydraulic power requirements. No other lifter has the gentle handling of all your expensive bins and such high ground clearance.

FOR MORE COMPREHENSIVE INFORMATION, CONTACT:

MECHLIFT (Pty) Ltd, 84 Mobile Road, 7490, Rep. of South Africa
Telephone: +27 21386 0404, Telefax: +27 21 385 1886
Website: www.mechlift.com, E-mail: info@mechlift.com



DIMENSIONS:

MECHLIFT 805

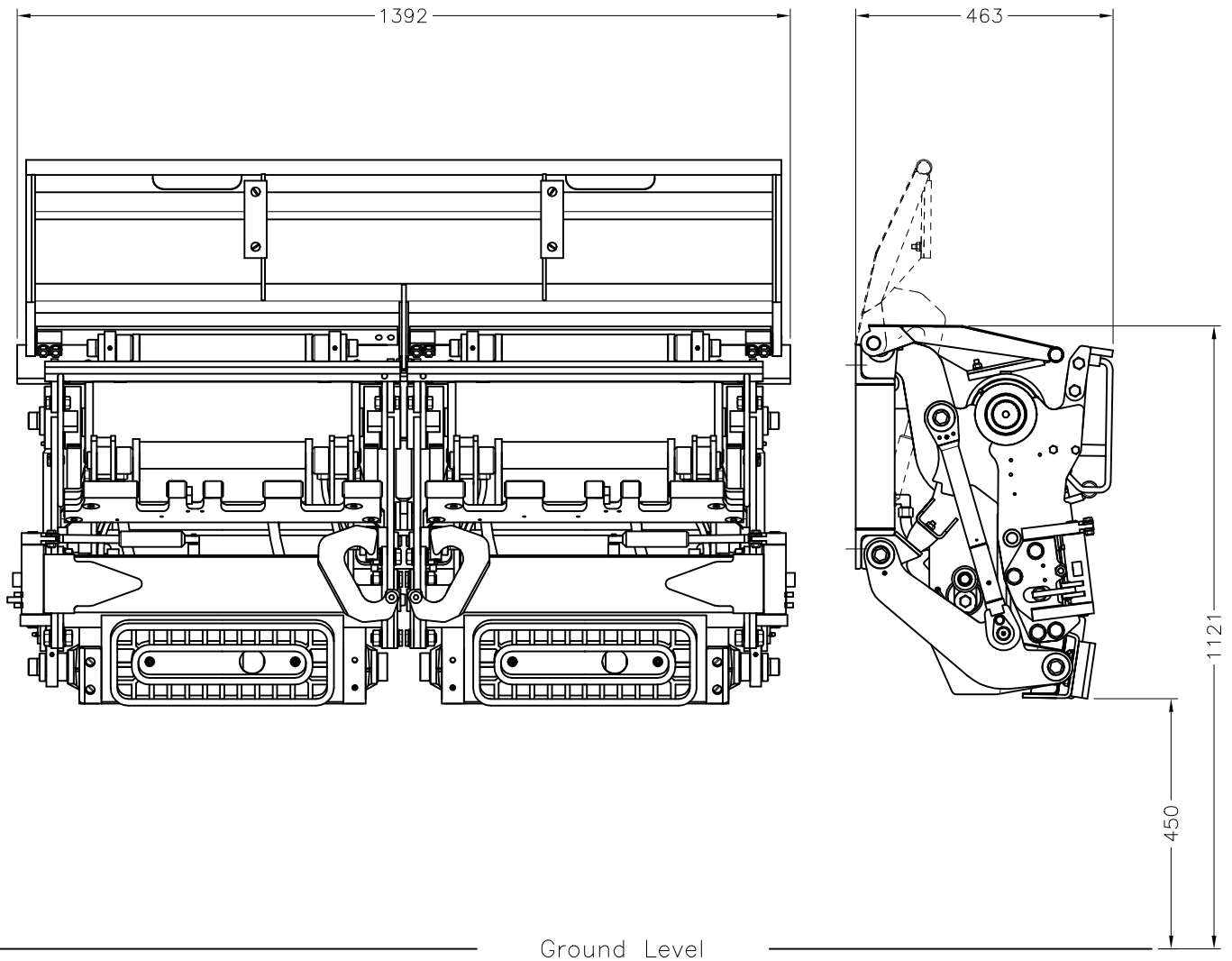

SPECIFICATIONS:

DIN/MGB BIN SIZES:

60 to 360 litre SPLIT COMB

500 to 1100 litre COMBINED COMB

CYCLE TIME: 8 sec. min. SPLIT COMB

15 sec. min. COMBINED COMB

LIFTING CAPACITY:

700 kg (at 150 bar setting)

MASS: 390 kg

HYDRAULIC REQUIREMENTS

HYDRAULIC PRESSURE:

180 bar SUPPLY PUMP CAPACITY
(lower pressures and loads adjustable)

HYDRAULIC FLOW:

28 litre/min for 8 sec. cycle time

FEATURES:

Automatic interlocking of combs when trunnion arms are opened, no exposed hydraulic cylinder rods to get damaged and ingest dirt, damage in the event of collisions is limited to inexpensive components, can be maintained by normal workshop personnel without any special training.