

DIMENSIONS:

MECHLIFT 220R

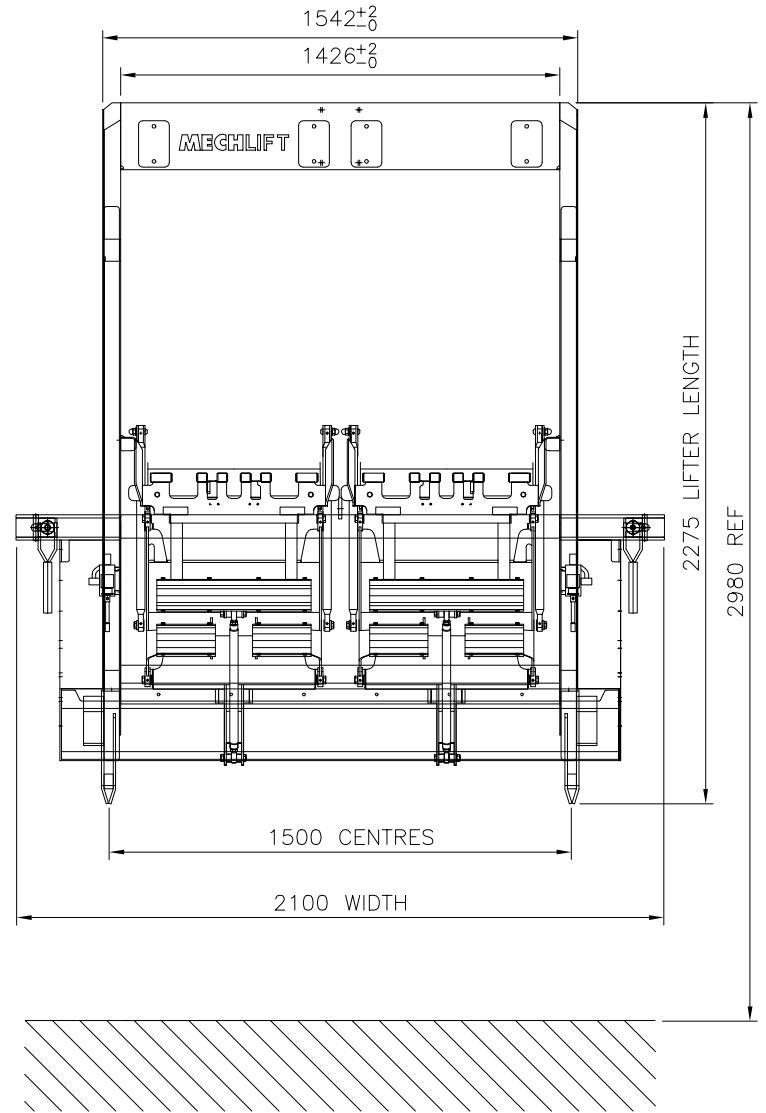
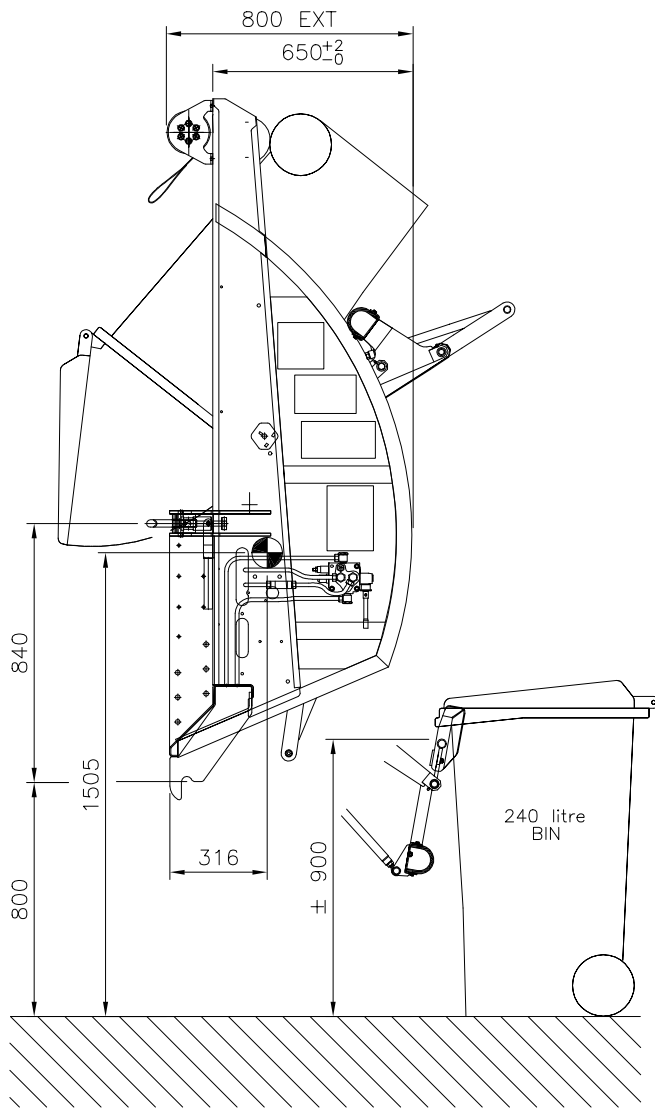

FOR INSTALLATION AND MORE COMPREHENSIVE DETAILS, PLEASE VISIT WWW.MECHLIFT.COM

SPECIFICATIONS:

LIFTER TYPE:	High Level Lifter
BIN TYPE:	1 x 240 litre per lifter (two)
CYCLE TIME:	7 – 8 seconds
TIPPING ANGLE:	55 degrees
LIFTING CAPACITY:	150 Kg per lifter (adjustable limit) (exceeds bin rating by 50%)
HYDRAULIC PRESSURE:	130 bar (relief valve set at 150 bar)
HYDRAULIC FLOW:	18 litre/min for 8 sec. cycle time
NOISE LEVEL:	< 72 dBA
SHIPPING DIMENSIONS:	2275 x 2100 x 800mm
LIFTER MASS:	530 Kgs

FEATURES:

1. Demountable – easily transferred or removed during skip handling
2. No tools – are required to remove the lifter from the truck
3. Winch – a winch overload protection clutch is used to raise and lower the lifter. This slip release mechanism prevents the lifter frame from being bent.
4. Weight – this is kept to the minimum due to the unique frame and rocker combination, thus resulting in bigger pay loads
5. High Level – can still empty bins whilst the truck is compacting

OTHER:

The ML220R has maintenance-free bearings, no flexible hoses (all zinc-plated steel pipes), no exposed cylinder rods to be damaged or ingest dirt.

Damage in the event of an accident is generally inexpensive to repair because of this model's high ground clearance and simple design, this also makes for easy maintenance.