

# MECHLIFT ML 325 Bin Lifter



Over the past couple of years, the market place has shown more and more interest in the larger four wheeled bins, say bins from 600 to 800 litres. It is with this in mind that the ML 325 has been designed. The ML 325 is a single comb high level lifter capable of handling virtually all DIN/MGB bins, right from the 120 litre bin to 1100 litre bin. It can also fitted with trunnion lift arms and an adjustable lid opener for the larger "Spriko" bins. (sold as optional extras)

The ML 325 boasts a ground clearance of over 400mm, which means there is much less chance of the lifter getting damaged. Bare in mind, 90% of lifter damage and repair costs are suffered when the lifter is in the full down position.

The ML 325 uses the same technology as the ML 310, which has proven it's self to be one of the best high level lifters on the market over the past ten years. The single comb means that the larger bins are easily loaded and emptied. It also means that only a single operator is required and since there are fewer working parts, maintenance and purchase costs are reduced.



Non standard model shown here, klap-arms are an optional extra.



As with all Mechlifft bin lifters, the ML 325, mostly makes use of standard parts, in its construction. This means, for example, that you will readily find most of the bearings, are available from your regular bearing suppliers.

You will also find that spares and comprehensive back up service are always readily available for this locally designed and manufactured lifter. Mechlifft prides itself on its prompt response time and availability of spare parts, should they be required.

FOR MORE COMPREHENSIVE INFORMATION, CONTACT:

MECHLIFT (Pty) Ltd, 84 Mobile Road, Airport Industria, Cape Town, 7490, South Africa  
Telephone: +27 21 386 0404, Telefax: +27 21 385 1886  
E-mail: [info@mechlifft.com](mailto:info@mechlifft.com), Website: [www.mechlifft.com](http://www.mechlifft.com)



## DIMENSIONS:

# MECHLIFT 325

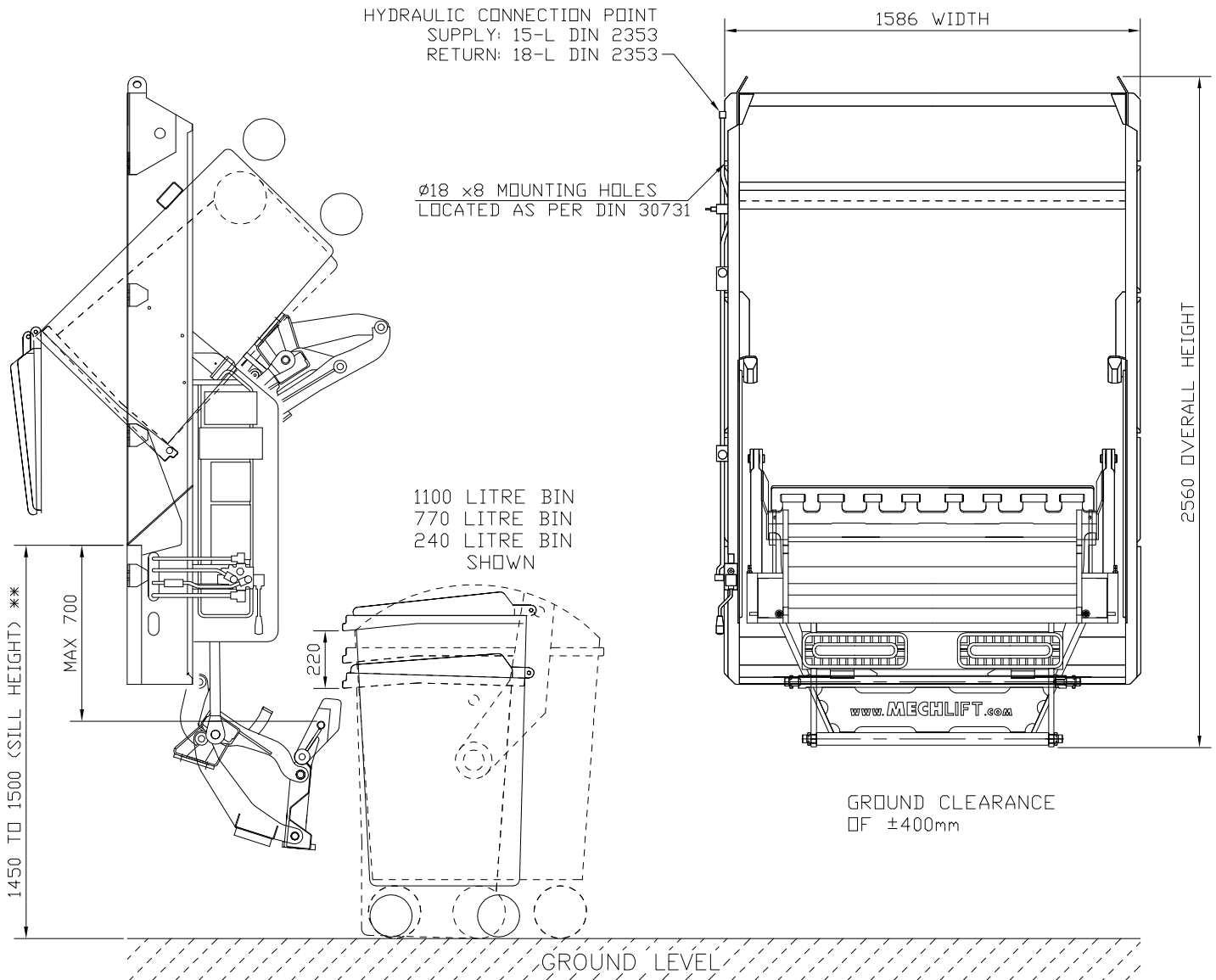

**	BIN TYPE	SILL HEIGHT
	240 TO 1100L	1450 - 1500
	500 TO 1100L	1450 - 1700

MASS: 525 kgs  
ALL DIMENSIONS IN MM

## SPECIFICATIONS:

DIN/MGB BIN SIZES: 240 to 770 litre (standard model)  
240 to 1100 litre (klaparm kit model)

CYCLE TIME: 12 sec. min.

LIFTING CAPACITY: 700 kg (at 160 bar setting)

HYDRAULIC PRESSURE: 160 bar SUPPLY PUMP CAPACITY

HYDRAULIC FLOW: 32 litre/min

## OPTIONS:

Lifter can be fitted with Klaparms and retractable lid opener for use with 1100 litre dome lidded bins and "Spriko" type bins.

## FEATURES:

One of the few lifters which is capable of lifting virtually all the different types of DIN/MGB bins.

No flexible hoses (all pipes are zinc-plated steel), no exposed cylinder rods to get damaged and ingest dirt.

Due to the ample ground clearance, the chance of the lifter getting damaged or fouled is greatly reduced.

Lifter can easily be maintained by ordinary workshop personnel. No special training or tools are required.