

# MECHlift ML 450 Bin Lifter



## Spare Parts Catalogue

- Prices 1<sup>st</sup> January 2011 -





# CONTENTS:

ML450 Bin Lifter Assembly - Overview .....	4
.. <i>Frame Assembly -- Identify the part names</i> .....	5
Main Frame Assembly .....	6
Upper Shackle Assembly .....	7
Lower Shackle Assembly .....	8
Actuator Carriage Assembly .....	9
Cross Shaft Assembly .....	10
.. <i>Swing Frame and Hub Assembly -- Identify the part names</i> .....	11
Swing Frame Assembly .....	12
Spline Hub & Swing Plate Assembly .....	13
Comb Frame Assembly .....	14
Over Tip Restrainer Assembly .....	15
Hydraulics .....	16
Actuator Service Parts .....	17
Notes .....	18



**Where to contact Mechlift? See page 19**

**Note to Partsman:**

- Always quote the Mechlift part numbers when ordering parts
- Part numbers ending in 1 usually refer to Left Hand Side parts
- Part numbers ending in 2 usually refer to Right Hand Side parts

If in doubt, please feel free to contact Mechlift, we are always willing to help (contact details on page 17)

# ML 450 BIN LIFTER ASSEMBLY

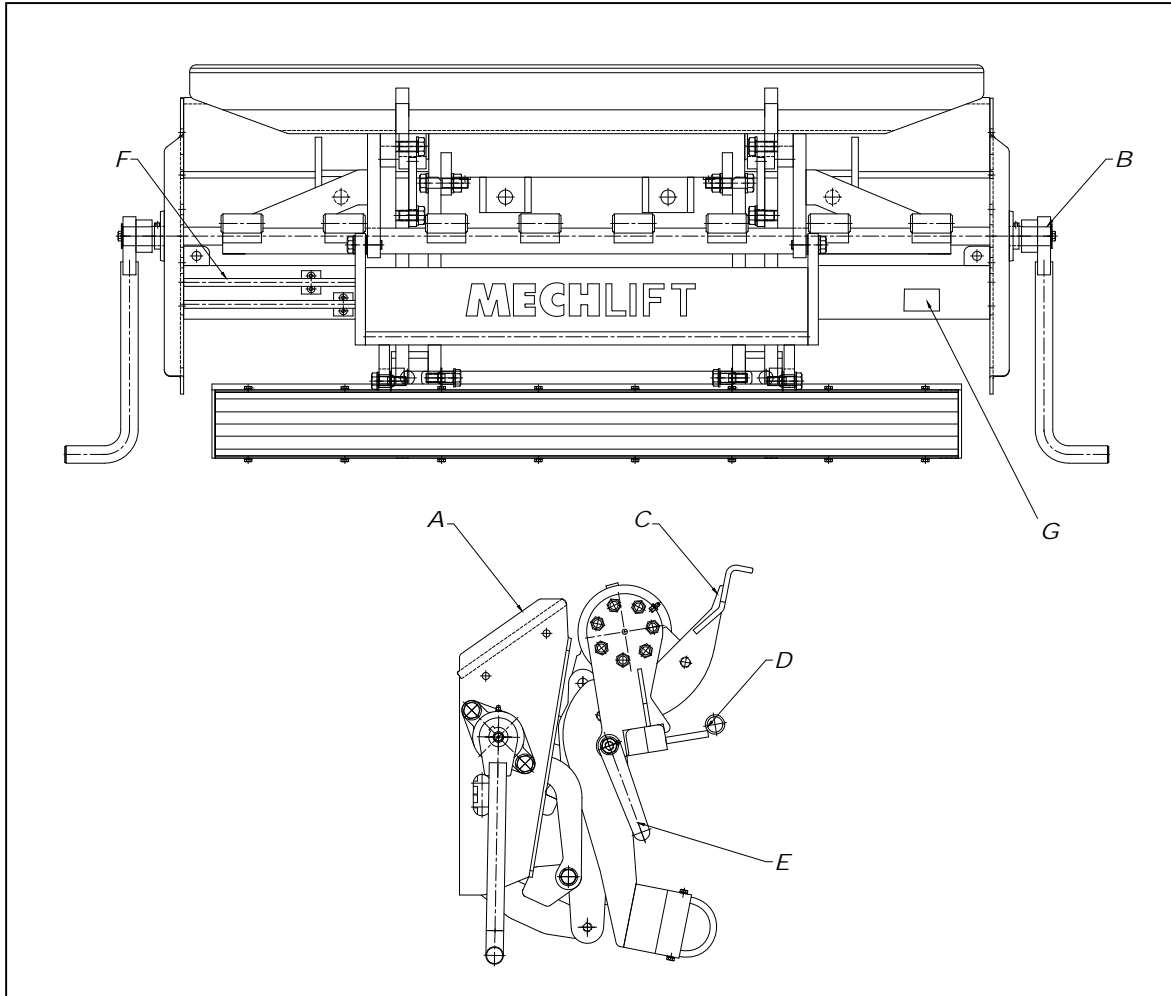

## Overview

Ref	PART
A	MAIN FRAME ASSEMBLY - includes Actuator Carriage, Upper and Lower Shackles
B	CROSS SHAFT ASSEMBLY for raising the lifter - includes handles, bearings, link plates and L Link plates
C	SWING FRAME ASSEMBLY - includes Spline Hubs & Swing Plates ( LH and RH are the identical)
D	COMB FRAME ASSEMBLY
E	OVER TIP RESTRAINER
F	HYDRAULICS -includes actuator, pipes, hoses, hydraulic fittings
G	<b>SERIAL AND MODEL NUMBERS are here.</b> ( lower right side of lifter )

# FRAME ASSEMBLY

Part Number: 45 90 000 A

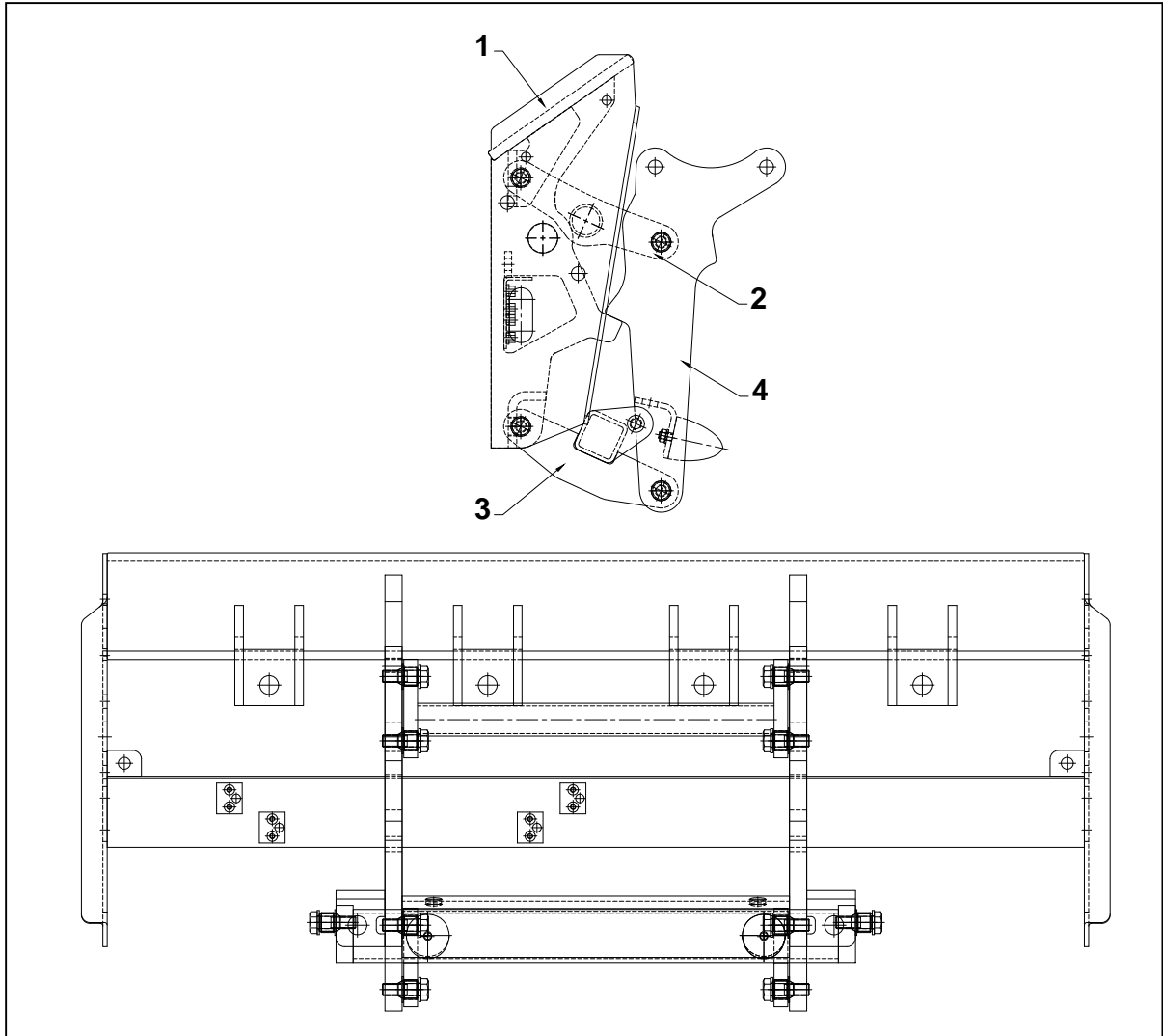

**WHAT ARE THE ABOVE PARTS CALLED? See below**

Ref	Part No.	Part
1	45 91 100 A	MAIN FRAME
2	45 41 100 A	SHACKLE UPPER ASSEMBLY
3	45 41 110 A	SHACKLE LOWER ASSEMBLY
4	45 91 200 A	ACTUATOR CARRIAGE

# MAIN FRAME ASSEMBLY

Part Number: 45 91 100 A

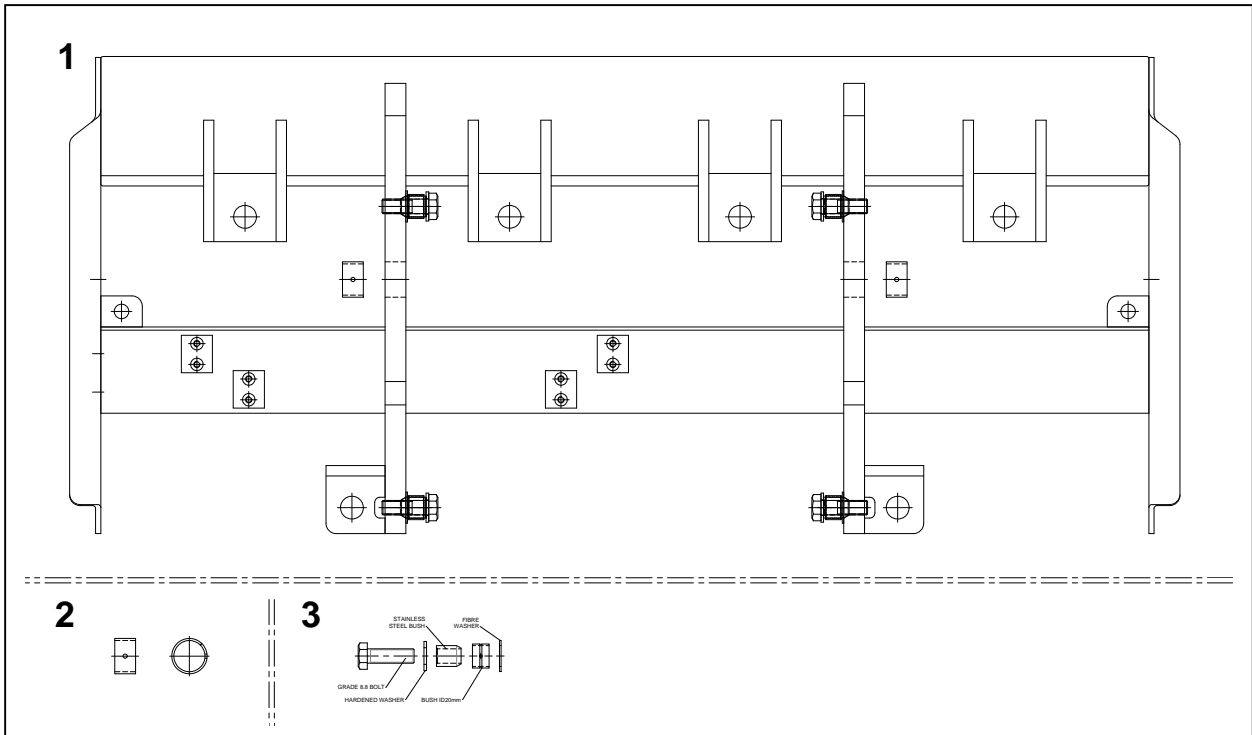

Block	Part No.	Part	Qty	Unit Price
1	45 91 100 A	MAIN FRAME ASSEMBLY (Includes blocks 2 & 3)	1	R7 146.30
2	BPAP3020P20	PERMAGLIDE BUSH	2	R 73.20
3	07 90 105 K	JOINT SERVICE KIT 450 (SS Taper Nose Bush)	2	R 193.40
4	07 90 104 K	JOINT SERVICE KIT (Capscrew and Nut)	2	R 199.90

# SHACKLE UPPER ASSEMBLY

Part Number: 45 41 100 A

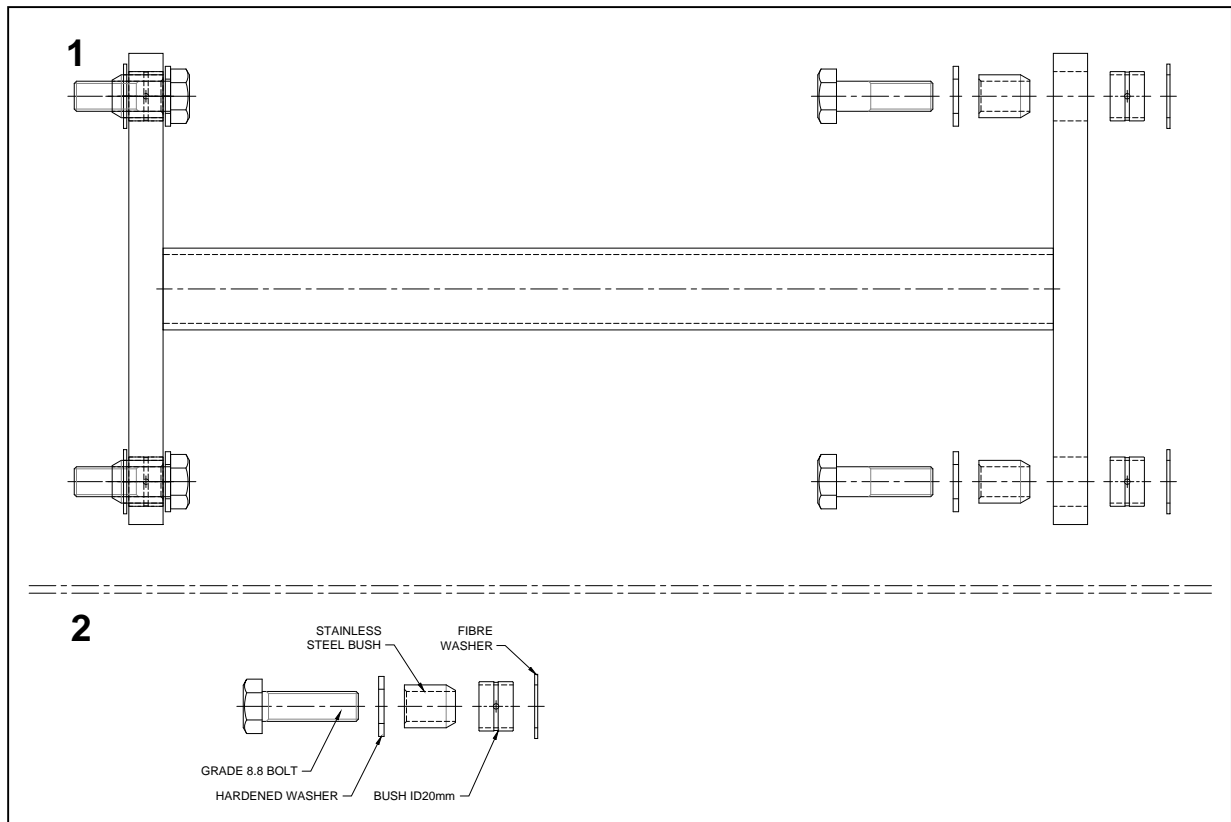

Block	Part No.	Part	Qty	Unit Price
1	45 41 100 A	SHACKLE UPPER ASSEMBLY (Includes block 2 + 3)	1	R2 384.50
2	07 90 105 K	JOINT SERVICE KIT 450 (SS Taper Nose Bush)	2	R 193.40
3	07 90 104 K	JOINT SERVICE KIT (Capscrew and Nut)	2	R 199.90

# SHACKLE LOWER ASSEMBLY

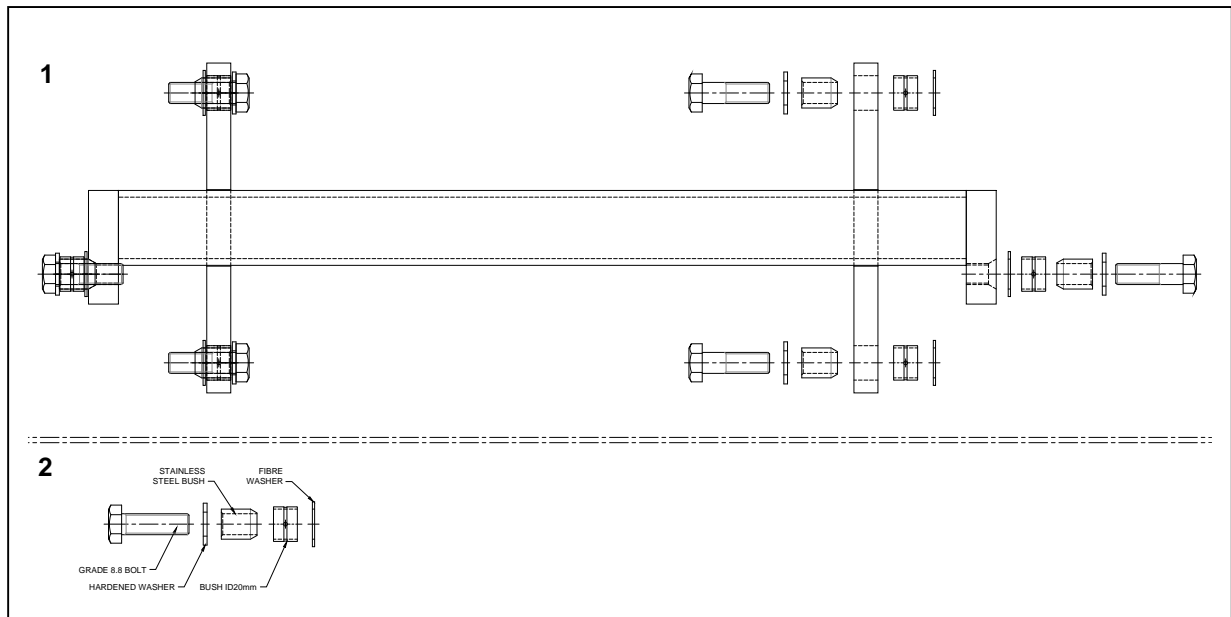

Block	Part No.	Part	Qty	Unit Price
1	45 41 110 A	SHACKLE LOWER ASSEMBLY (Includes block 2)	1	R3 541.10
2	07 90 105 K	JOINT SERVICE KIT 450 (SS Taper NoseBush)	6	R 193.40

# ACTUATOR CARRIAGE ASSEMBLY

Part Number: 45 91 200 A

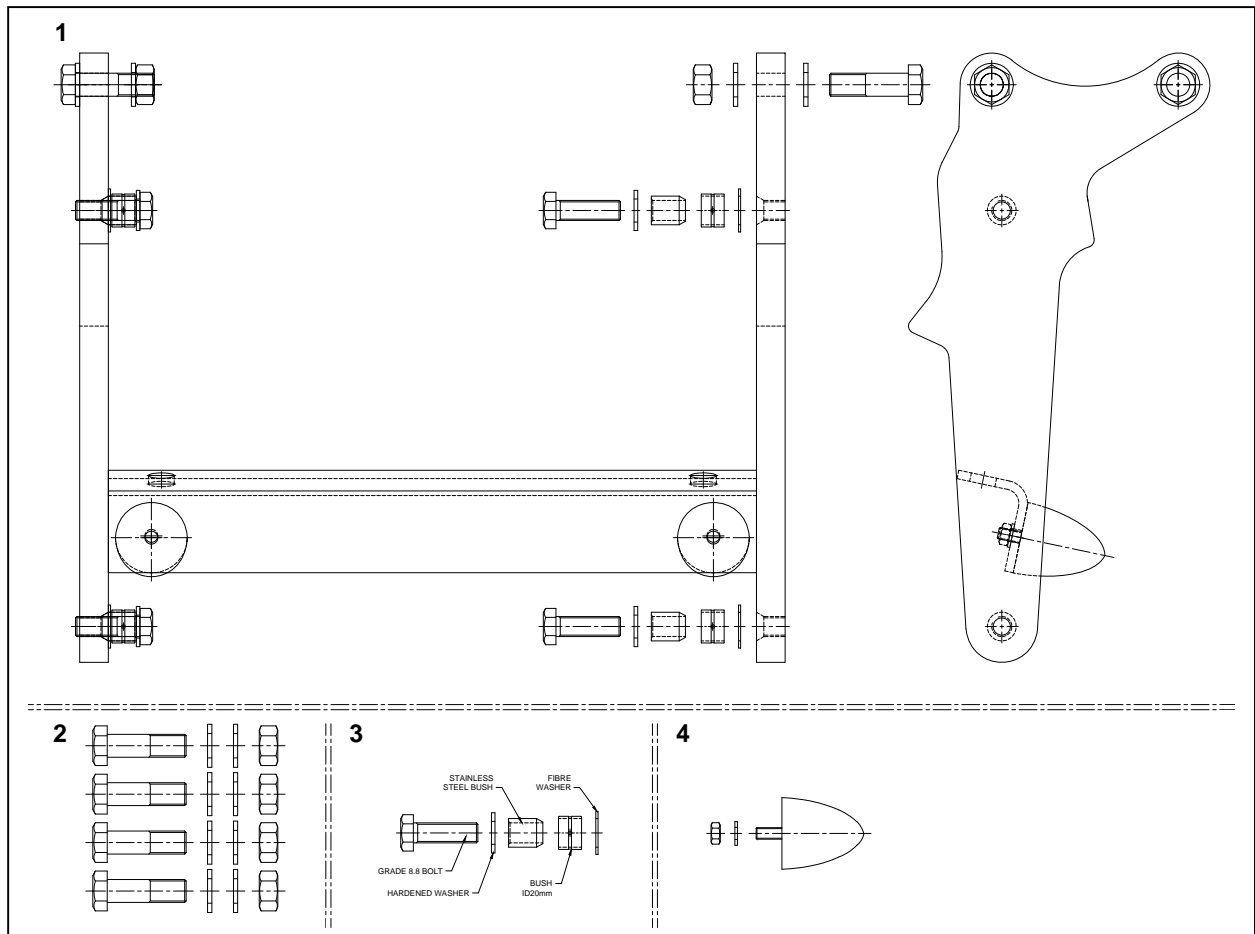

Block	Part No.	Part	Qty	Unit Price
1	45 91 200 A	ACTUATOR CARRIAGE ASSEMBLY (Includes blocks 2, 3, & 4)	1	R3 839.60
2	07 90 106 K	BOLT KIT – ACTUATOR	1	R 98.60
3	07 90 105 K	JOINT SERVICE KIT 450 (SS Taper Nose Bush)	2	R 193.40
4	05 10 115 K	CONICAL BUMP RUBBER KIT	2	R 145.00
5	07 90 104 K	JOINT SERVICE KIT (Capscrew and Nut)	2	R 199.90

# CROSS SHAFT ASSEMBLY

Part Number: 45 42 000 A

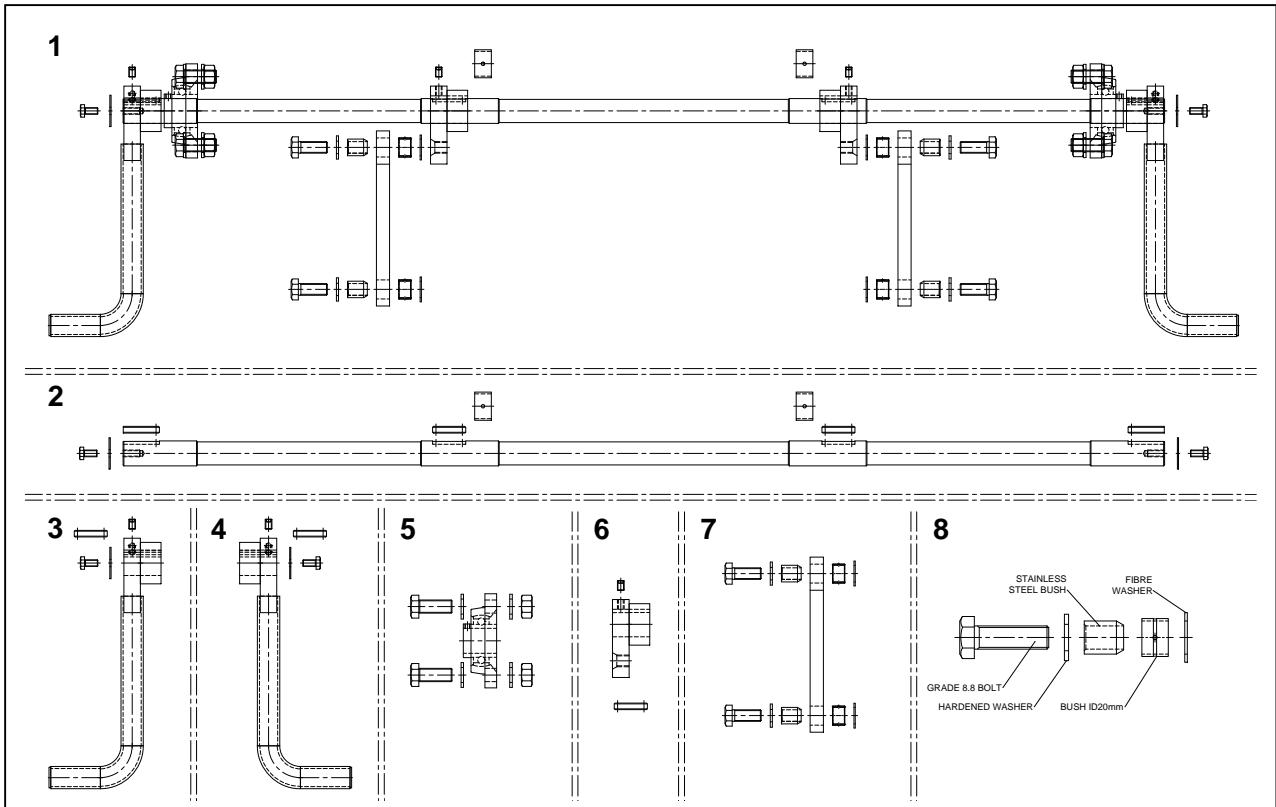

Block	Part No.	Part	Qty	Unit Price
1	45 42 000 A	CROSS SHAFT ASSEMBLY (includes blocks 2, 3, 4, 5, 6 & 7)	1	R5 052.25
2	45 42 103 A	CROSS SHAFT (including keys – bushes on page 8)	1	R1 604.30
3	45 42 121 A	HAND LEVER ASSEMBLY - LEFT	1	R1 553.80
4	45 42 122 A	HAND LEVER ASSEMBLY - RIGHT	1	R1 553.80
5	07 94 401 K	SHAFT BEARING KIT	2	R 221.70
6	45 42 105 A	LINK PLATE ASSEMBLY	2	R 892.40
7	45 42 115 A	L LINK ASSEMBLY	2	R 754.20
8	07 90 105 K	JOINT SERVICE KIT 450 (SS Taper Nose Bush)	4	R 193.40

# SWING FRAME & HUB ASSEMBLY

Part Number: 45 70 000 A

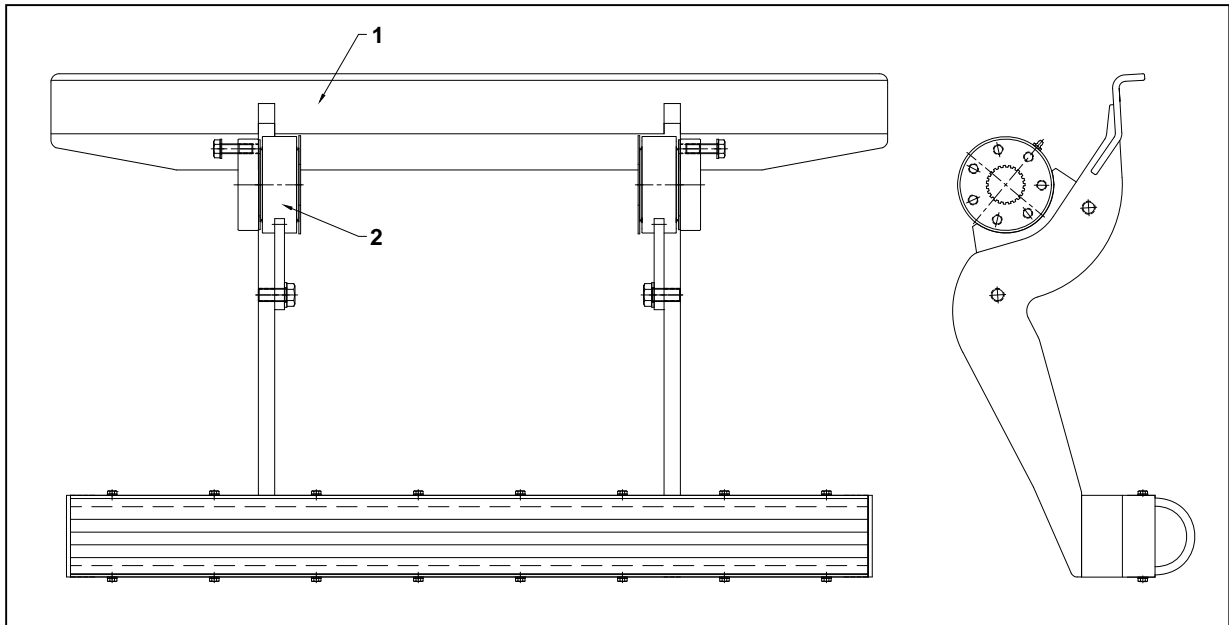

**WHAT ARE THE ABOVE PARTS CALLED? See below**

Number	Part No.	Part	Page
1	45 71 100 A	SWING FRAME ASSEMBLY	12
2	45 42 000 A	SPLINE HUB and SWING PLATE ASSEMBLY	13

# SWING FRAME ASSEMBLY

Part Number: 45 71 100 A

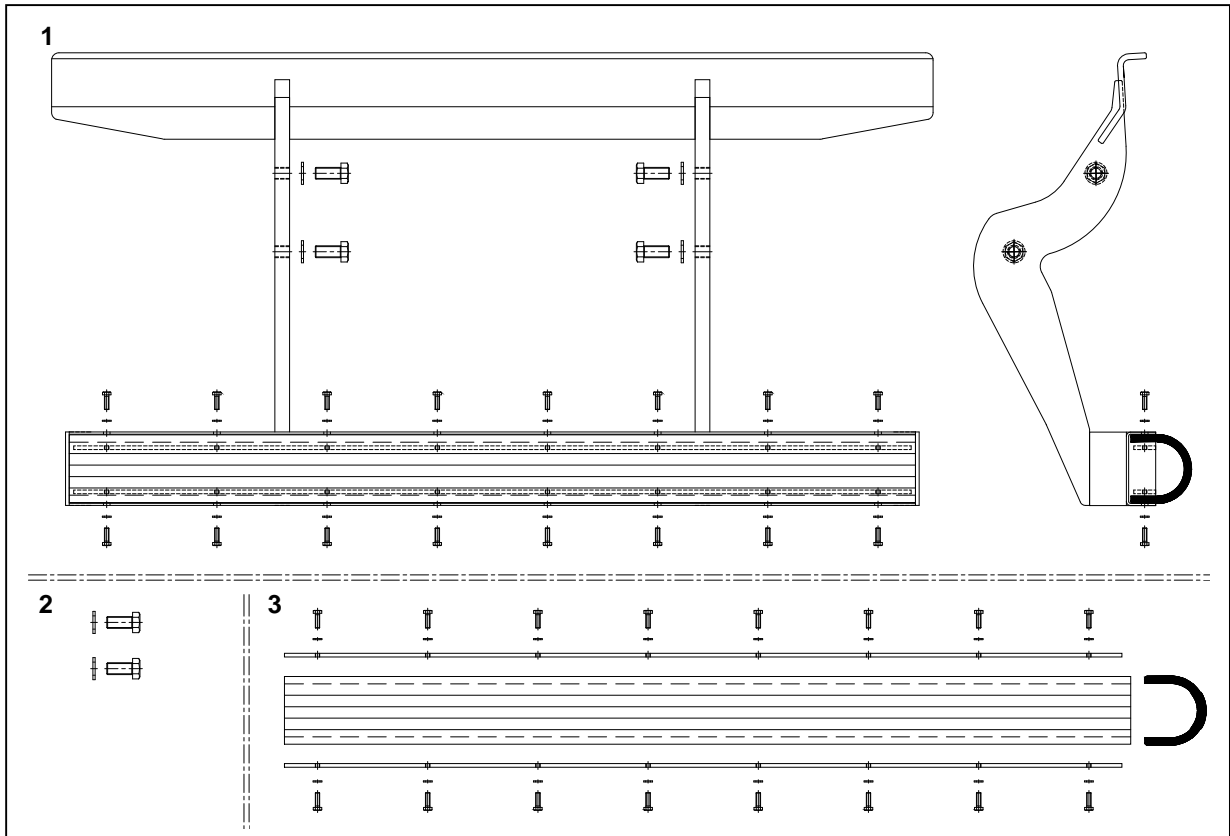

Block	Part No.	Part	Qty	Unit Price
1	45 71 100 A	SWING FRAME ASSEMBLY (Includes blocks 2, 3 & 4)	1	R5 932.00
2	07 90 110 K	BOLT KIT –SWING FRAME/ FULCRUM ARM	2	R 25.85
3	07 94 701 K	KIT RUBBER PUSH PAD – ML 450	1	R 868.60

# SPLINE HUB & SWING PLATE ASSY

Part Number: 45 20 000 A

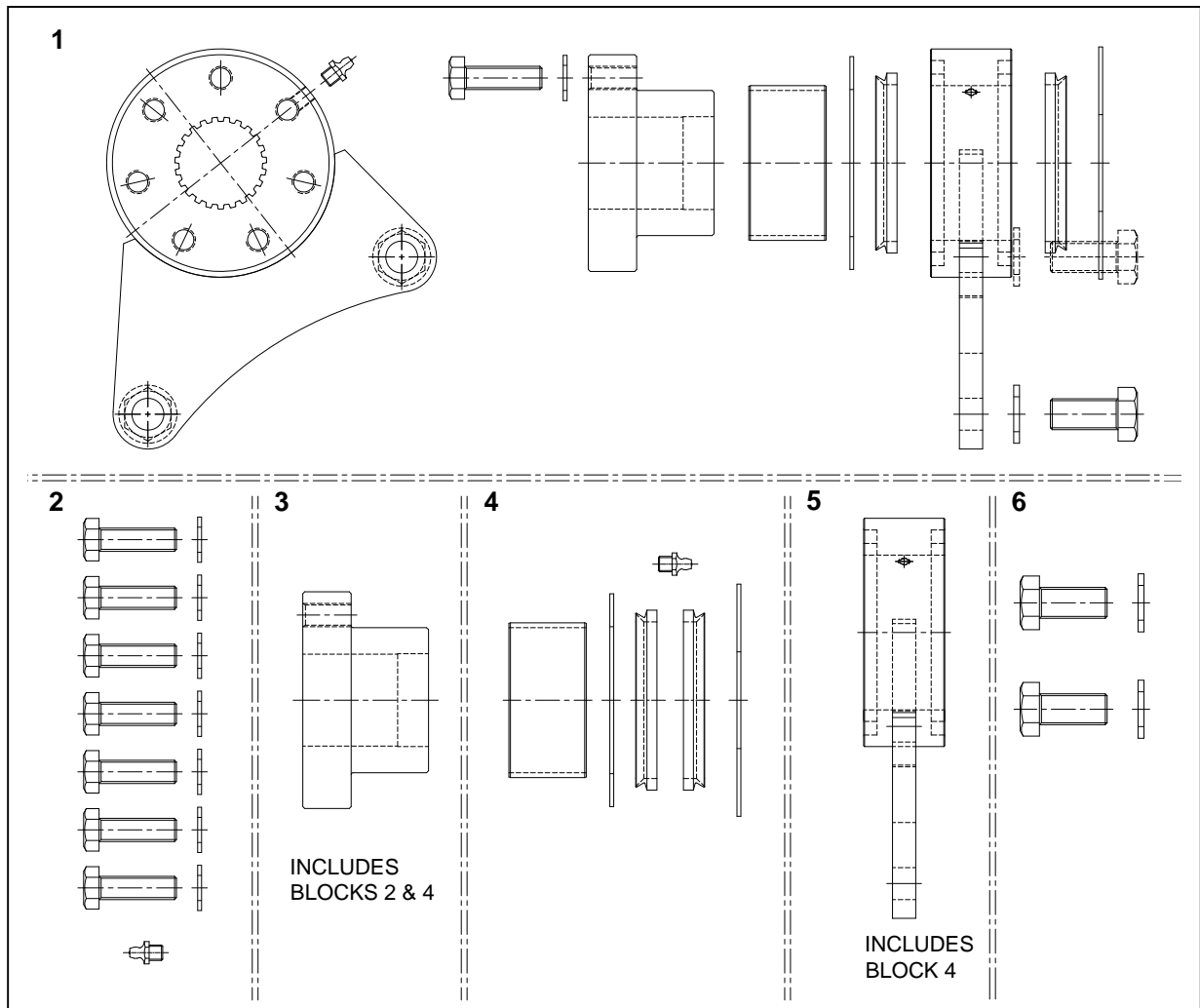

Block	Part No.	Part	Qty	Unit Price
1	45 20 000 A	FULCRUM HUB ASSEMBLY – LH or RH (Includes blocks 2, 3, 4, 5 & 6)	2	R3 840.00
2	07 90 111 K	BOLT KIT – FULCRUM ARM	1	R70.40
3	45 21 020 A	SPLINED HUB (Includes blocks 2 & 4)	1	R2 858.00
4	07 94 201 K	WEAR KIT – ML 450	1	R686.30
5	45 22 100 K	SWING FRAME PLATE KIT (Includes block 4)	1	R1 784.50
6	07 90 110 K	BOLT KIT – SWING FRAME/ FULCRUM ARM	1	R25.85

# COMB PLATE ASSEMBLY

Part Number: 45 50 000 A

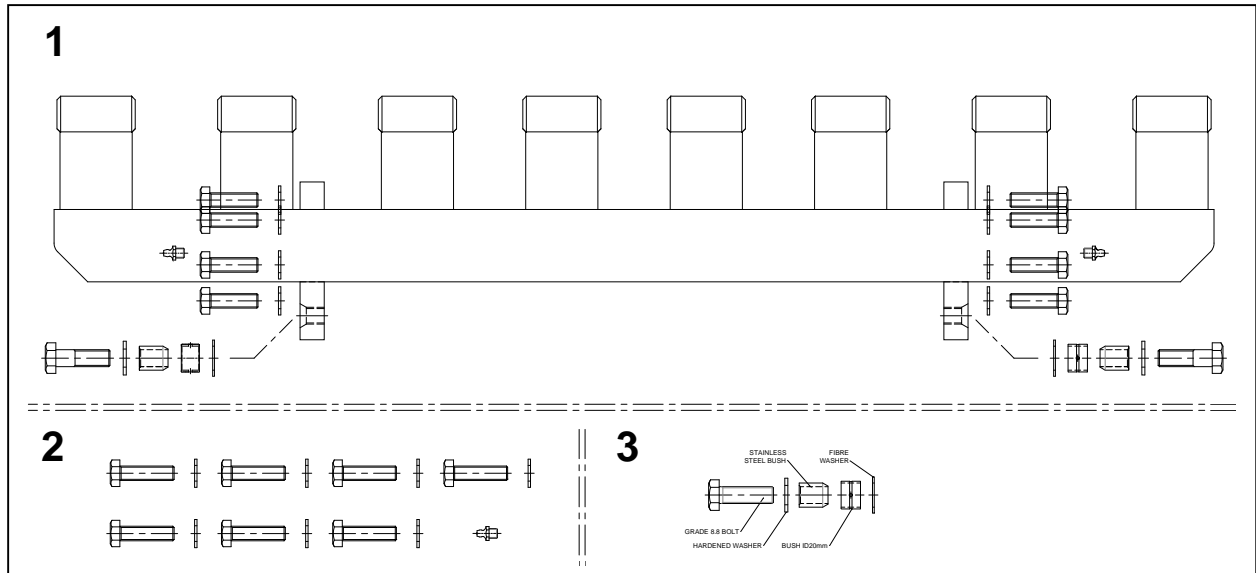

Block	Part No.	Part	Qty	Unit Price
1	45 50 000 A	COMB PLATE ASSEMBLY (Includes blocks 2, 3, 4 & 5)	1	R4 317.40
2	07 90 111 K	BOLT KIT – FULCRUM ARM 450	2	R70.40
3	07 90 105 K	JOINT SERVICE KIT 450 (SS Taper Nose Bush)	2	R193.40

# OVER TIP ASSEMBLY

Part Number: 45 60 000 A

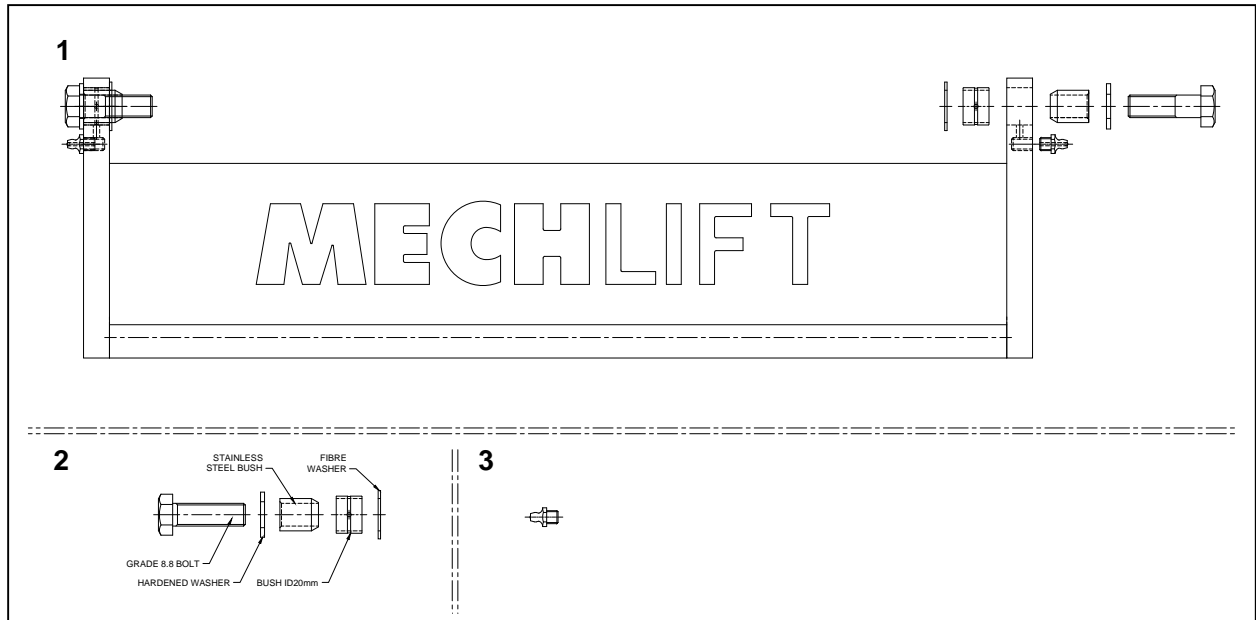

Block	Part No.	Part	Qty	Unit Price
1	45 60 000 A	OVER TIP ASSEMBLY (Includes blocks 2 & 3)	1	R1 880.60
2	07 90 105 K	JOINT SERVICE KIT 450 (SS Taper Nose Bush)	2	R179.10
3	MGN 08	GREASE NIPPLE M8	2	R12.00

# HYDRAULIC SYSTEM

Part Number: 45 10 000 A

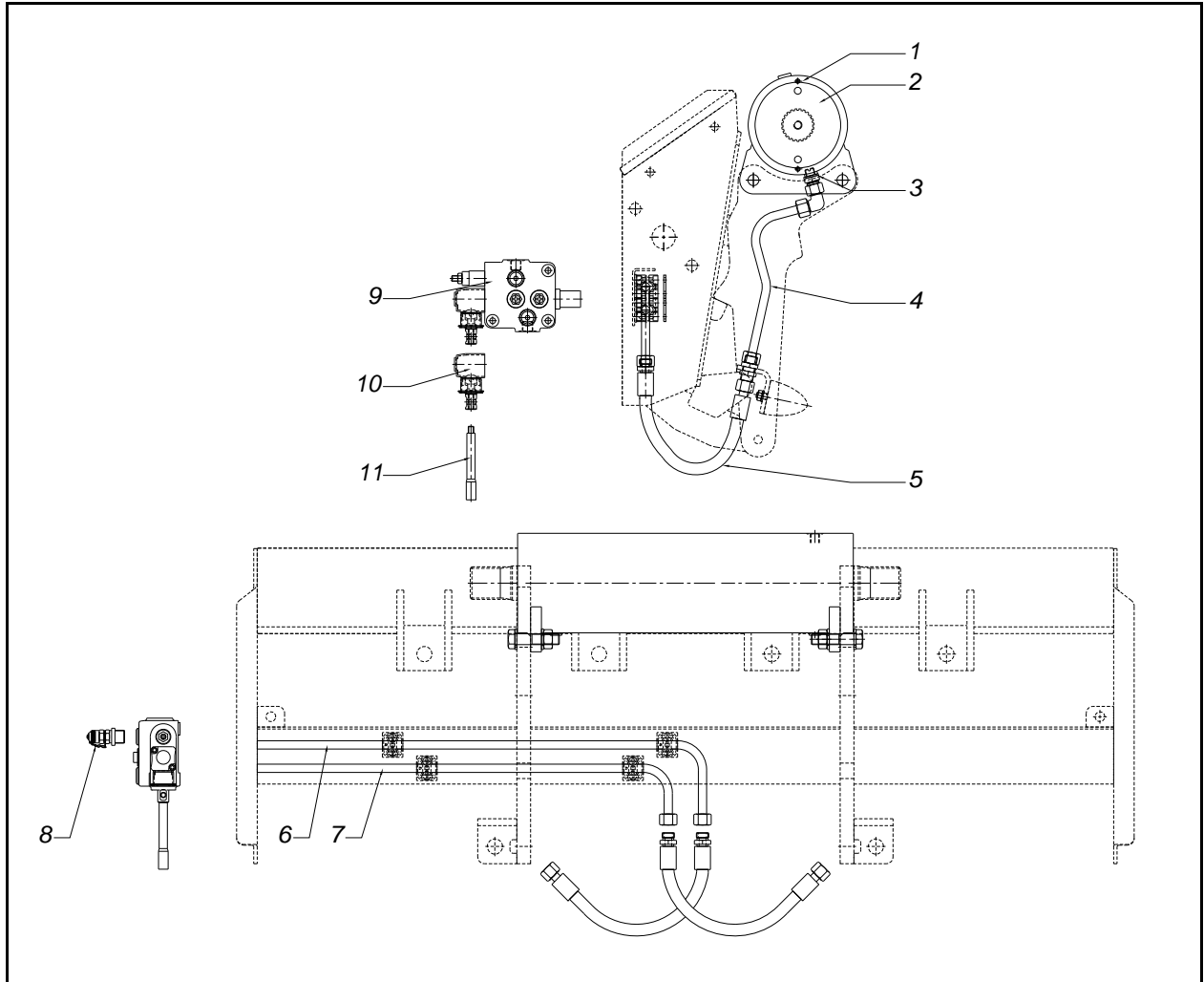

No.	PART No.	PART	Qty	Unit Price
1	08 10 141 X	ACTUATOR Model S2241	1	R35717.20
3	03 70 001 E	SPECIAL FITTING – ACTUATOR PORT	2	R 139.40
4	45 10 105 E	PIPE – ACTUATOR TO CARRIAGE	2	R 110.00
5	45 10 100 J	FLEXIBLE HOSES	2	R 292.05
6	45 10 103 E	PIPE - UPPER	1	R 115.00
7	45 10 104 E	PIPE - LOWER	1	R 115.00
8	HMINI 3.8	MINITEST COUPLING	1	R 222.00
9	45 10 110 A	CONTROL VALVE	1	R2 680.00
10	HV VCD BOX	LEVER BOX ASSEMBLY (shaped square)	1	R 252.00
10b	HV VCD CAP	END CAP ASSY (shaped round & spring side)	1	R 172.00
11	01 40 010 A	VALVE HANDLE	1	R 140.00

# ACTUATOR SERVICE PARTS

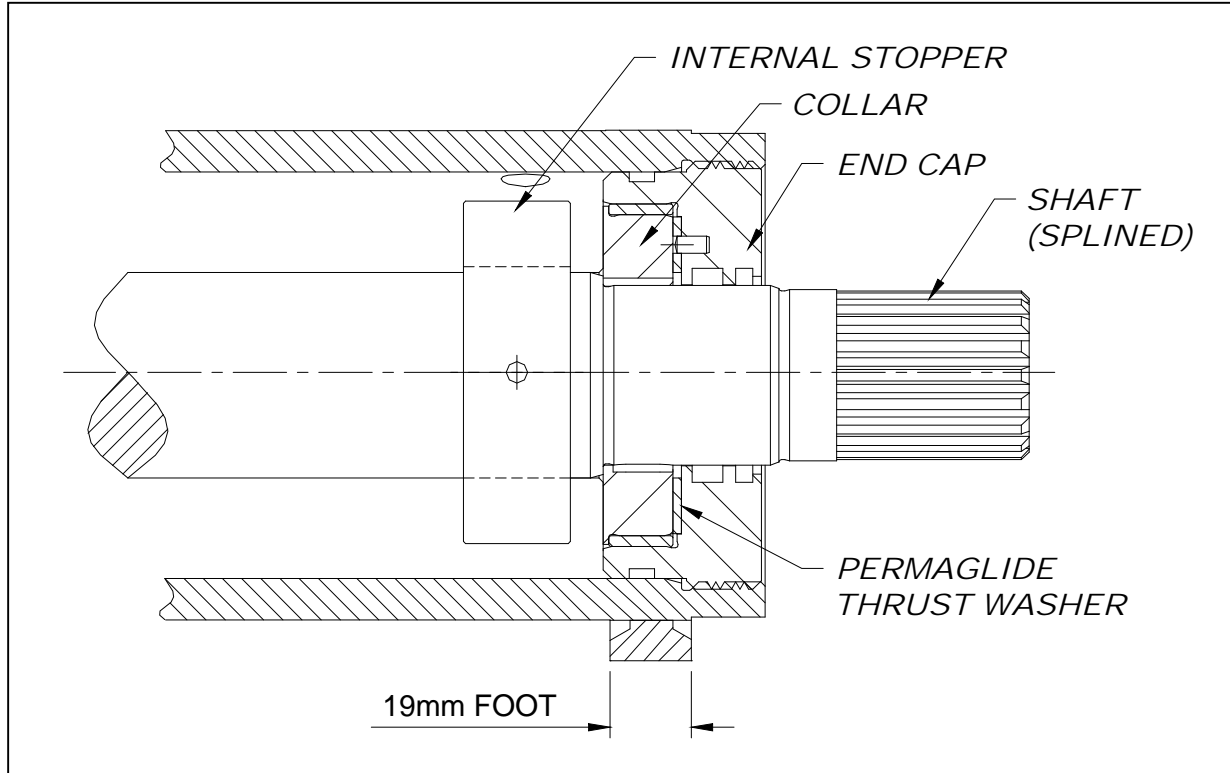

Part No.	Part	Qty	Unit Price
08 10 140 X	ACTUATOR Model S2241	1	R35 717.20
A SKH22 000	SEAL & BRG KIT – For full overhaul (Genuine OEM) (includes stopper , thrust washers and seals)	1	R5 361.45
A SKH22 300	SEAL KIT – End cap side only (Genuine OEM) (includes wiper, seal, o’ring, backup ring)	2	R 862.40
06 10 241 T	ACTUATOR INTERNAL STOPPER <b>(use only genuine OEM part)</b>	1	R 411.75
BPAW 62 P10	THRUST WASHER	2	R409.60
--	SHAFT – EURO S2241 (ex works only)	1	POA
--	COLLAR ( only sold as part of End Cap below )	2	--
08 10 144 X EC	END CAP Complete with collar, seals, thrust washer	2	R4 445.00

***NB***

Observe internal timing marks ***BEFORE*** pulling piston and shaft from barrel

**Make your notes below**



# Contact information:

Please feel free to contact us should you have any queries or need any further information:

Telephone:	+27 (0) 21 386 0404
Fax:	+27 (0) 21 385 1886
E-mail:	info@mechlift.com
Web address:	www.mechlift.com
Physical Address:	84 Mobile Road Airport Industria Cape Town 7490 South Africa
Postal Address:	84 Mobile Road Airport Industria Cape Town 7490 South Africa

***Please Note:***

This spare parts book is valid for the period: **1<sup>st</sup> January 2011 till 31<sup>st</sup> December 2011.**

The given price reflects the price for each unit, part or kit, some assemblies may require more than one of the same unit, part or kit.

Mechlift (Pty) Ltd reserves the right to change prices and /or part numbers without notification.

***Copyright ©***

This publication, or parts thereof, may not be reproduced in any form, by any method, for any purpose, without prior written permission from Mechlift (Pty) Ltd.

***Liability***

Whilst every attempt has been made to assure the accuracy of this manual, Mechlift (Pty) Ltd cannot accept responsibility for any errors, which may occur. All information given is subject to change without notice.

