

# MECHlift ML325 & ML325K Bin Lifter BOLT-ON MODEL



## Spare Parts Catalogue

- Prices effective 1<sup>st</sup> January 2011 -





# CONTENTS:

## **IDENTIFYING the lifter, finding its Model and Serial Number**

... ML 325 Bin Lifter Assembly – 240litre to 700litre bins .....	4
...ML 325K Bin Lifter Assembly – 240litre to 1100litre bins .....	5
<b>Lifter Sub Assembly QUICK REFERENCE GUIDE .....</b>	<b>6</b>
... NOTES page .....	7
Fulcrum Arm and Hub Assemblies LH & RH .....	8
Coupling .....	10
H Frame .....	11
Comb Frame .....	12
Long Link Rod .....	13
Lower Link Frame .....	14
Swing Frame .....	15
<b>Main Frame</b>	
Main Frame Assembly .....	16
Upper Stop Bracket .....	18
Coupling Retainer .....	19
Fulcrum Lock .....	20
Guard Frame – LH .....	21
Guard Frame – RH .....	22
Stopper Bar .....	23
Lid Opener .....	24
Lid Opener Control Mechanism .....	25
Bin Opener Pull Back Kit .....	26
Klaparms .....	27
<b>Hydraulics</b>	
Hydraulic System .....	28
Actuator Service Parts .....	30



**Where to contact Mechlif? See page 31**

### **Note to Partsman:**

- Always quote the Mechlif part numbers when ordering parts
- Part numbers ending in 1 usually refer to Left Hand Side parts
- Part numbers ending in 2 usually refer to Right Hand Side parts
- If in doubt, please feel free to contact Mechlif, we are always willing to assist

# ML 325 BIN LIFTER ASSEMBLY

Part Number: 35 00 000 A

**THE ML325 HAS A FIXED BIN STOPPER BAR FOR MAXIMUM 700litre TYPE BINS ONLY AND HAS NO LIFTING ARMS**

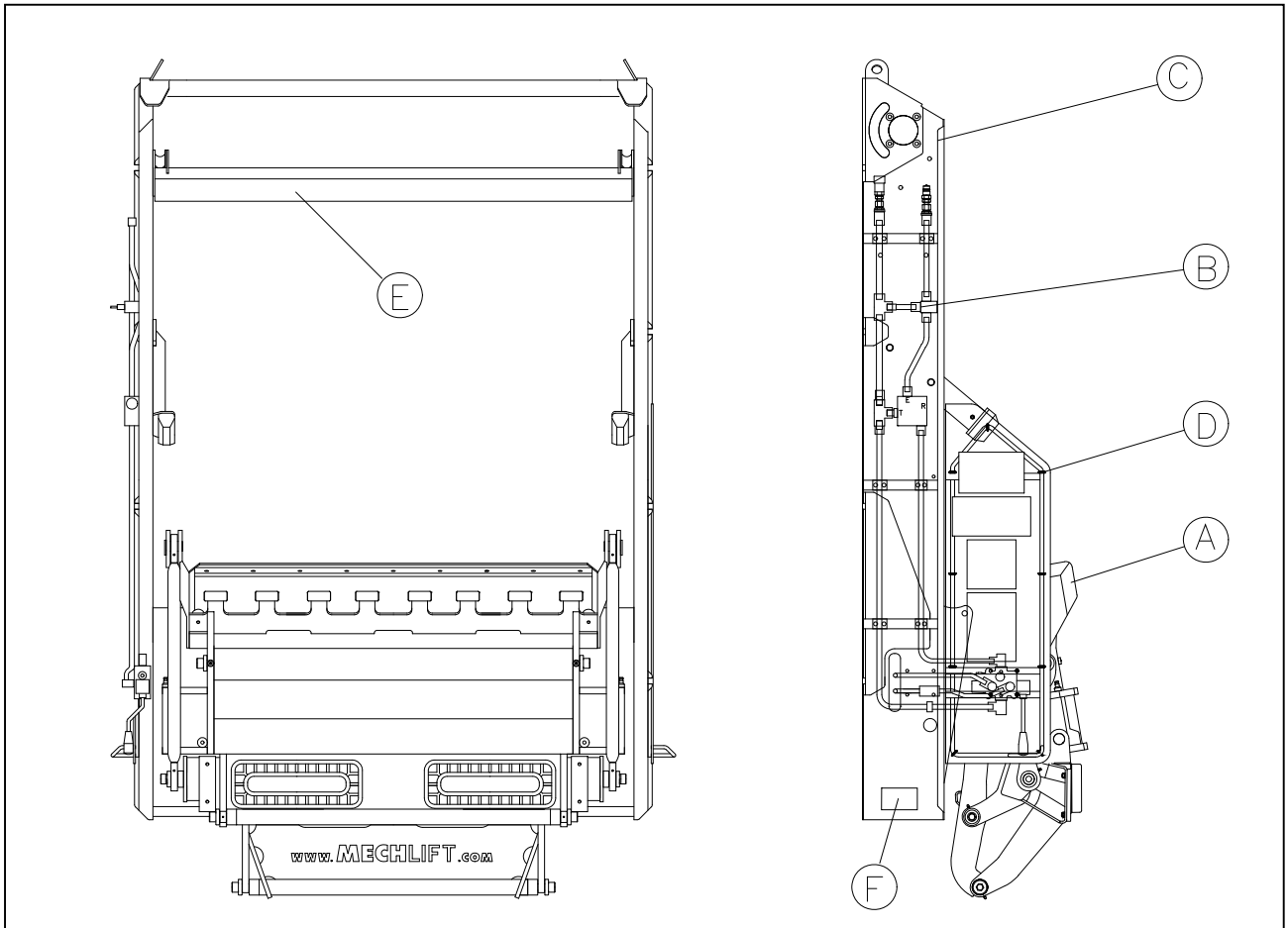

SECTION	PART
A	LIFTER ASSEMBLY See page 6 for greater detail
B	HYDRAULIC SYSTEM
C	MAIN FRAME ASSEMBLY
D	GUARD FRAMES - LH & RH
E	STOPPER BAR for bins of 240lit, 360 lit, 660lit and 700 litre maximum
F	<b>SERIAL AND MODEL NUMBERS are here.</b> ( lower left side of lifter )

# ML 325K BIN LIFTER ASSEMBLY

Part Number: 35 00 010 A

**THE ML325K HAS A SPRUNG LID OPENER AND FOLDING LIFTING ARMS FOR 1100litre BINS ON SPIGOTS**

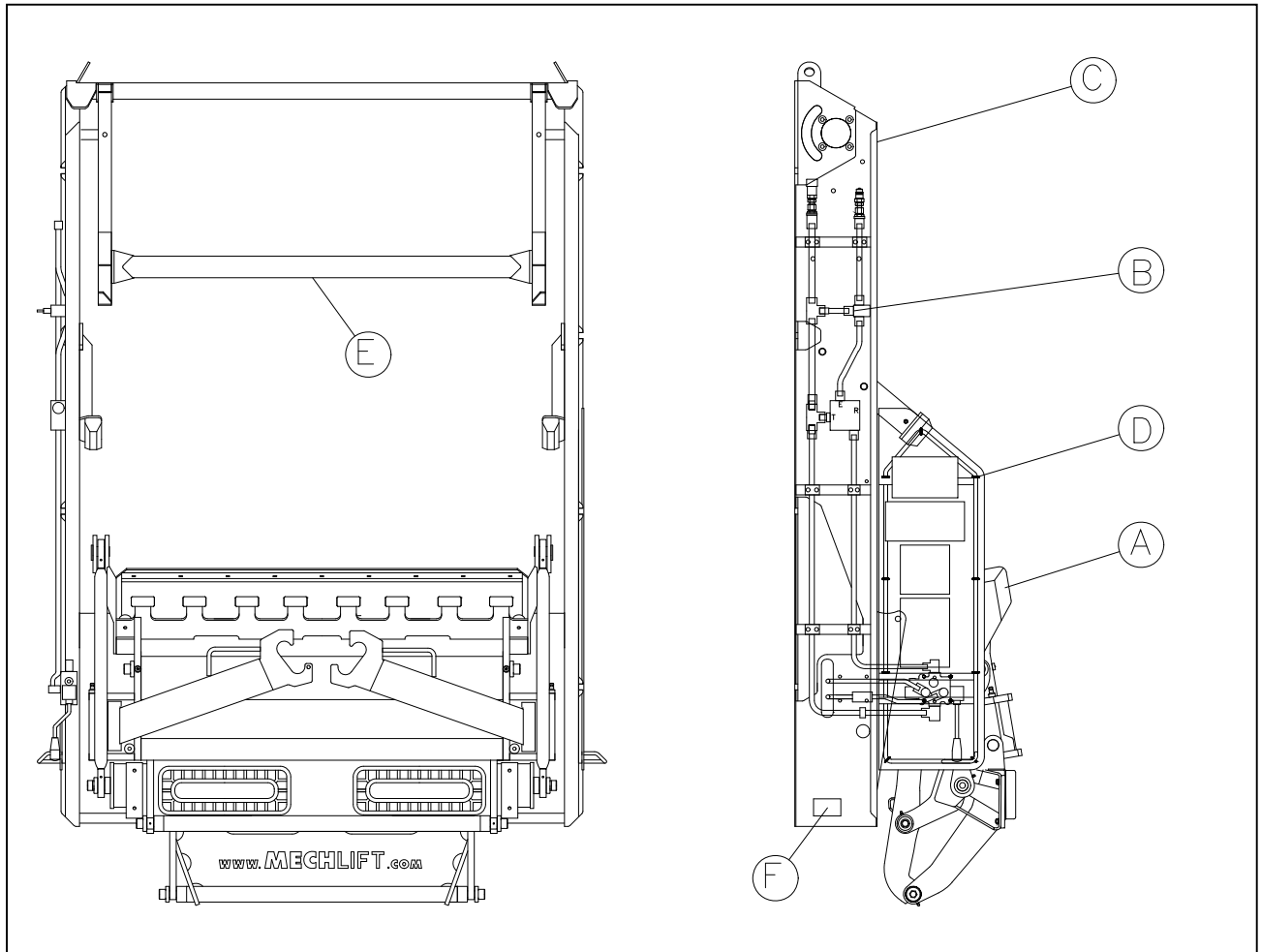

SECTION	PART
A	LIFTER ASSEMBLY See page 6 for greater detail
B	HYDRAULIC SYSTEM
C	MAIN FRAME ASSEMBLY
D	GUARD FRAMES - LH & RH
E	BIN CATCHER / LID OPENER for bins up to 1100litre on spigots. <b>For 1100litre bins on comb lifts, BIN OPENER PULL BACK KIT must be fitted. See elsewhere in this book</b>
F	<b>SERIAL AND MODEL NUMBERS are here.</b> ( lower left side of lifter ) OPTIONAL EXTRAS

# LIFTER SUB ASSEMBLIES

## QUICK REFERENCE

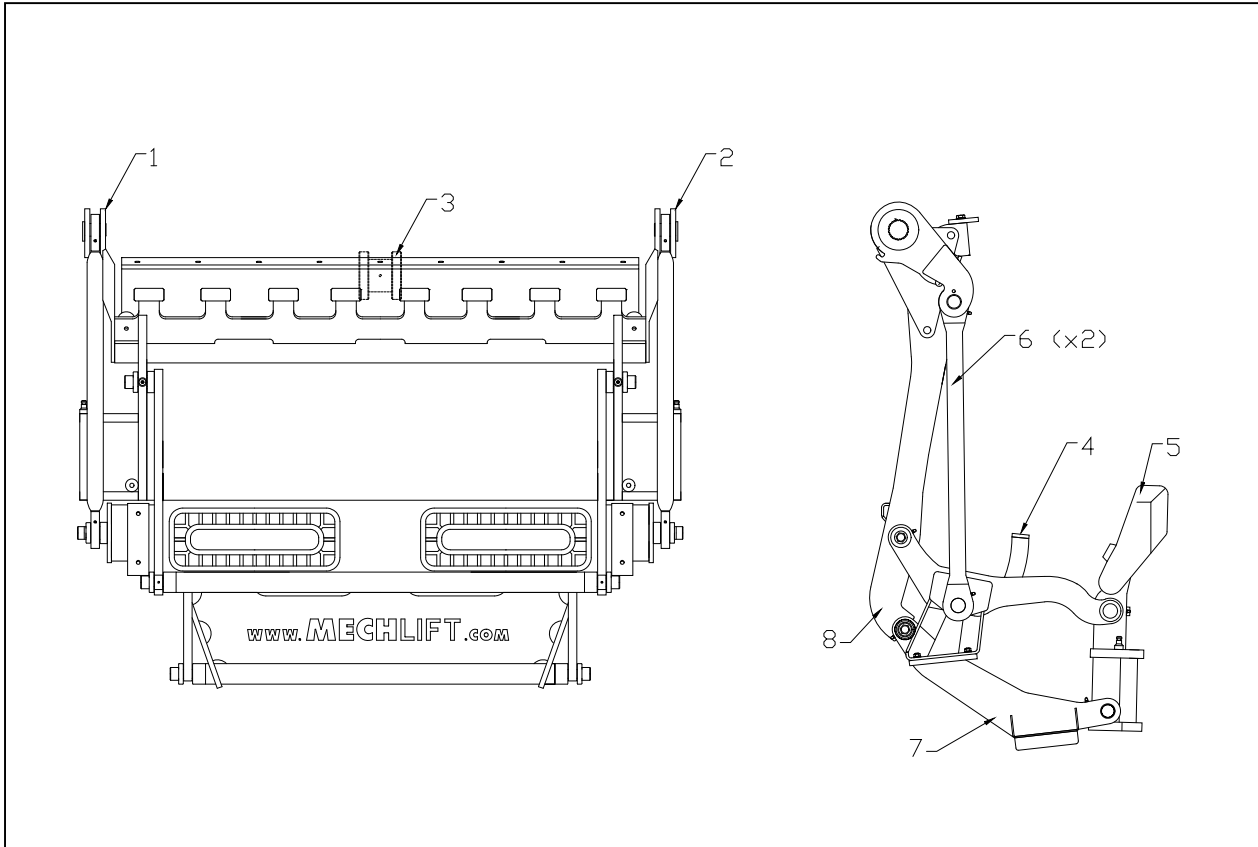

**This page tells you what the above parts are called and on what page to find them.**

No.	Part No.	Part	
1	35 21 001 A	FULCRUM ARM AND HUB ASSEMBLY - LEFT HAND	Page 8
2	35 21 002 A	FULCRUM ARM AND HUB ASSEMBLY - RIGHT HAND	Page 9
3	35 23 100 A	COUPLING ASSEMBLY (between the two actuator shafts)	Page 10
4	35 40 000 A	H-FRAME ASSEMBLY	Page 11
5	35 50 010 A	COMB FRAME ASSEMBLY (STANDARD)	Page 12
6	35 61 100 A	LONG LINK ROD ASSEMBLY	Page 13
7	35 62 100 A	LOWER LINK FRAME ASSEMBLY	Page 14
8	35 70 000 A	SWING FRAME ASSEMBLY	Page 15

**Make your notes below**



# FULCRUM ARM AND HUB ASSEMBLY - *LEFT HAND*

Part Number: 35 21 001 A

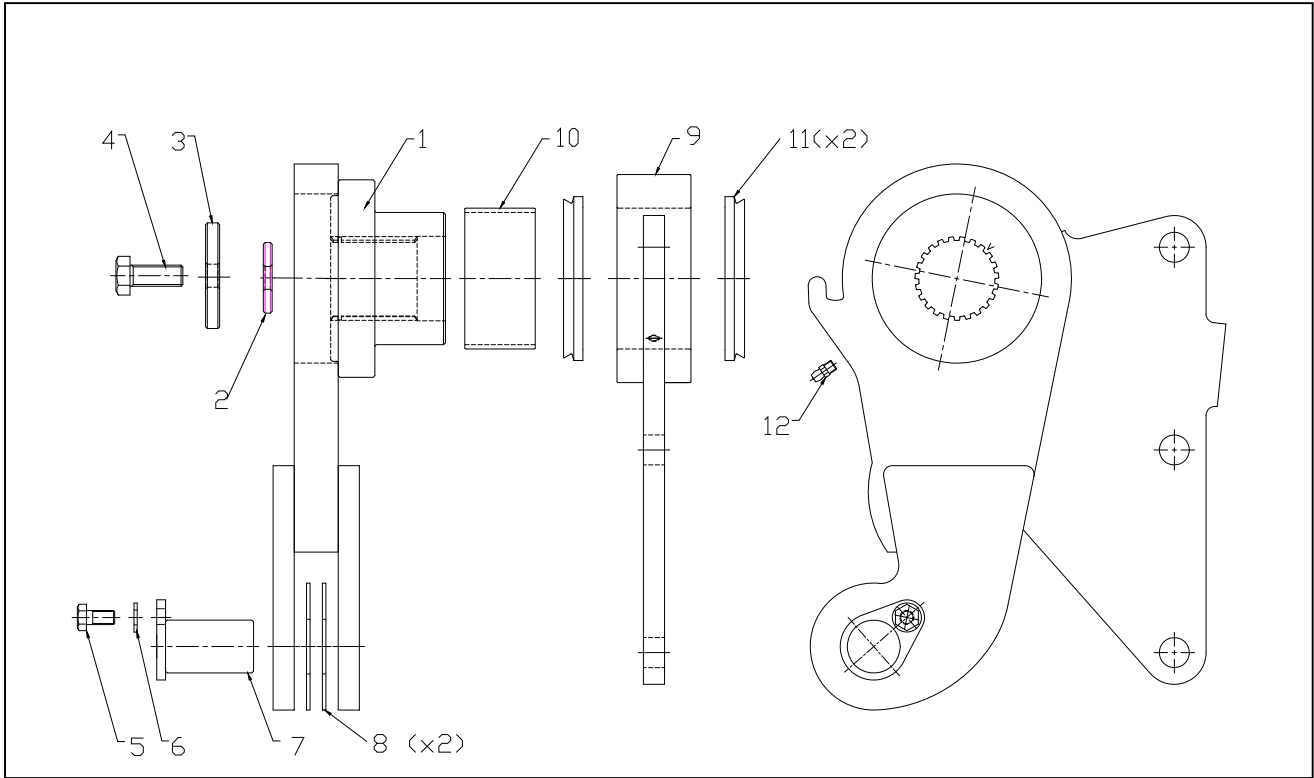

No.	Part No.	Part	Qty	Unit Price
	35 20 001 A	FULCRUM ARM & HUB ASSEMBLY LH (complete) Consists of all parts as shown	1	R4 847.00
1	35 21 001 A	FULCRUM ARM ASSY LH (incl item no's 1 to 8)	1	R3 306.85
9	35 22 100 A	SWING HUB PLATE ASSY (incl item no's 9 to 12)	1	R1 585.60
kit	07 93 210 K	KIT – Fulcrum arm service (incl item no's 2 to 8)	1	R 729.75
kit	07 93 220.K	KIT – Swing hub service (incl item no's 10 to 12)	1	R 572.50

# FULCRUM ARM AND HUB ASSEMBLY - *RIGHT HAND*

Part Number: 35 21 002 A

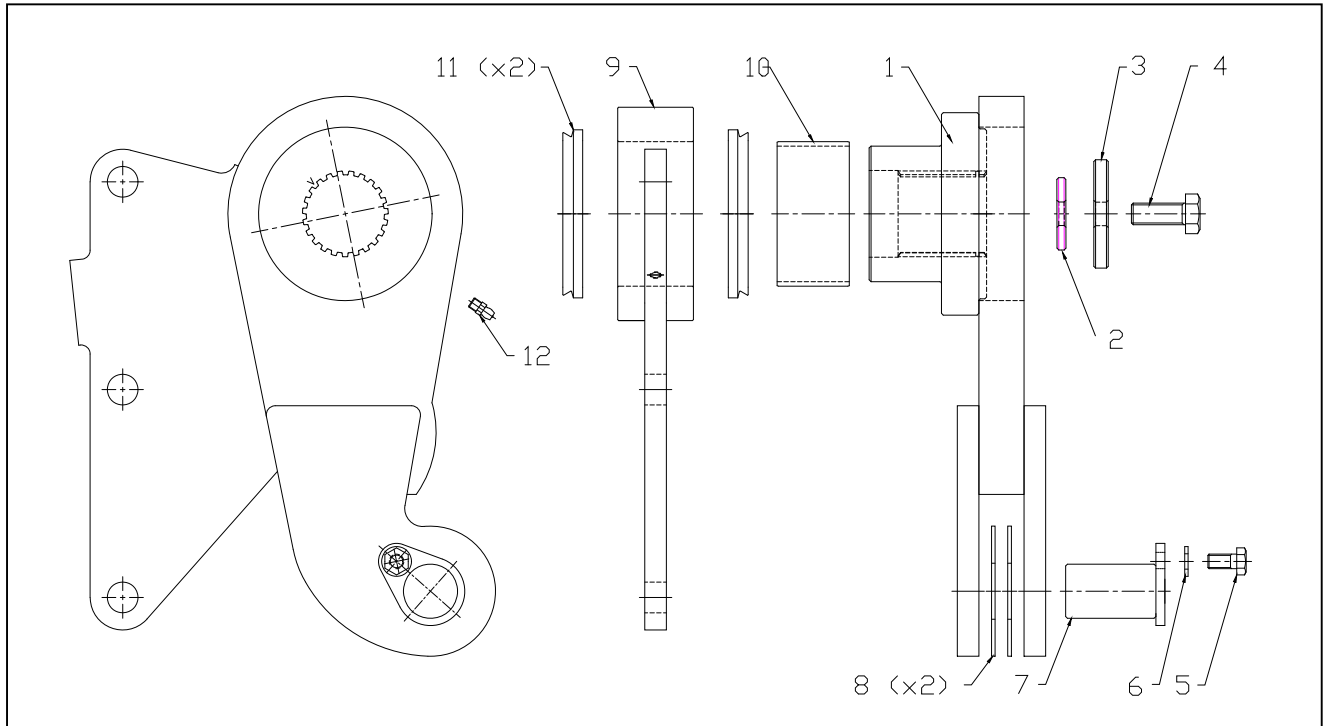

No.	Part No.	Part	Qty	Unit Price
	35 20 002A	FULCRUM ARM & HUB ASSEMBLY RH (complete) Consists of all parts as shown	1	R4 815.80
1	35 21 002 A	FULCRUM ARM ASSY RH (incl item no's 1 to 8)	1	R3 276.25
9	35 22 100 A	SWING HUB PLATE ASSY (incl item no's 9 to 12)	1	R1 585.60
kit	07 93 210 K	KIT – Fulcrum arm service (incl item no's 2 to 8)	1	R 729.75
kit	07 93 220.K	KIT – Swing hub service (incl item no's 10 to 12)	1	R 572.50

# COUPLING ASSEMBLY

Part Number: 35 23 100 A

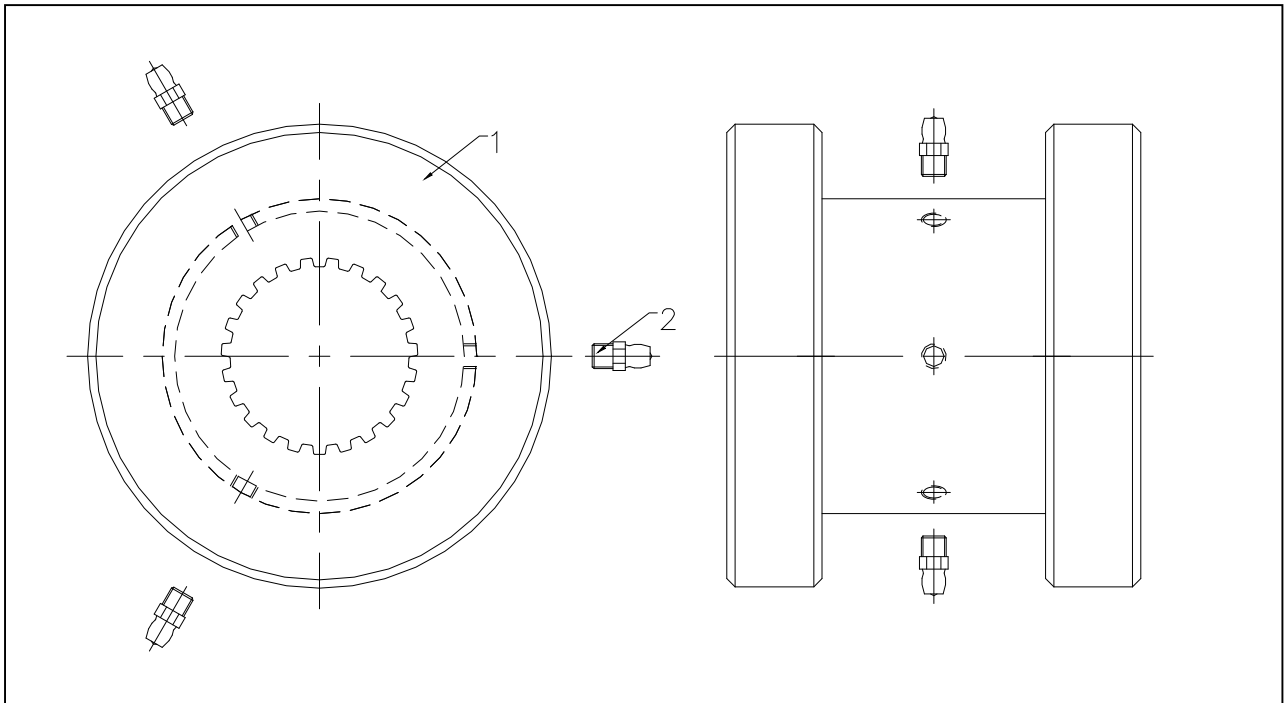

No.	Part No.	Part	Qty	Unit Price
	35 23100 A	COUPLING ASSEMBLY LH (complete)	1	R2 014.70
1	*NSS	Coupling weldment	1	-
2	MGN 06	Grease nipple	3	R 10.00

\* Not Sold Separately

# H-FRAME ASSEMBLY

Part Number: 35 40 000 A

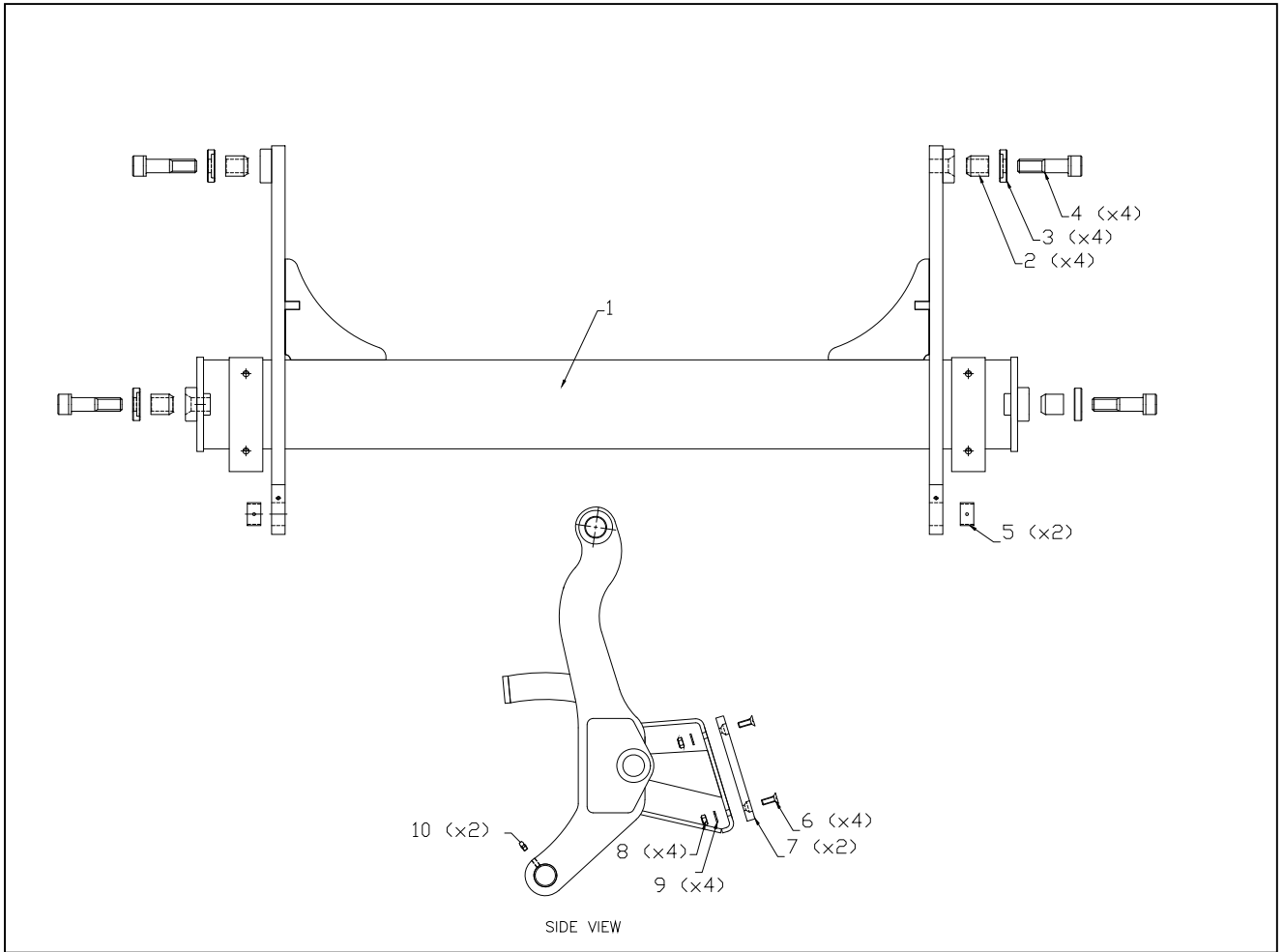

No.	Part No.	Part	Qty	Unit Price
	35 40 000 A	H-FRAME ASSEMBLY (complete with all parts shown)		R 9 030.00
1	* NSS	H-FRAME WELDMENT	1	-
kit	07 90 115 K	JOINT SERVICE KIT (incl item no's 2 to 5 and 10)	4	R 390.90
kit	07 93 410 K	KIT – Plastic pad (incl. Item no's 6 - 9)	2	R 263.90
5	BPAP 3020 P20	PERMAGLIDE BUSH	2	R 74.80

\* Not Sold Separately

# COMB FRAME ASSEMBLY

Part Number: 35 50 010 A

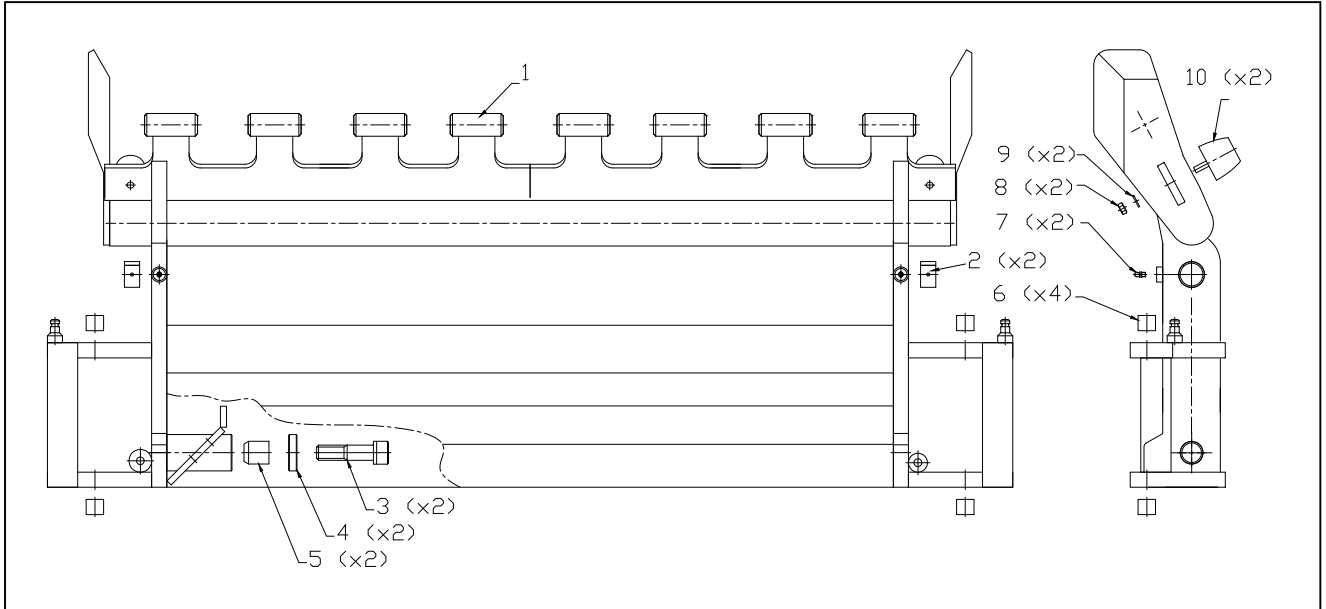

No.	Part No.	Part	Qty	Unit Price
	35 50 010 A	COMB FRAME ASSEMBLY (complete – no klaparms)	1	R11 848.85
1	* NSS	COMB FRAME WELDMENT	1	-
10	05 10 240 K	KIT – Conical bump rubber (Incl. item no's 8 to 10)	2	R 145.00
kit	07 90 115 K	JOINT SERVICE KIT (Incl item no's 2 to 5)	2	R 390.90
		Refer to Klaparm section for its 20mm bushes		
6	BPAP 3020 P20	PERMAGLIDE BUSH	2	R 74.80

\* Not Sold Separately

# LONG LINK ROD ASSEMBLY

Part Number: 35 61 100 A

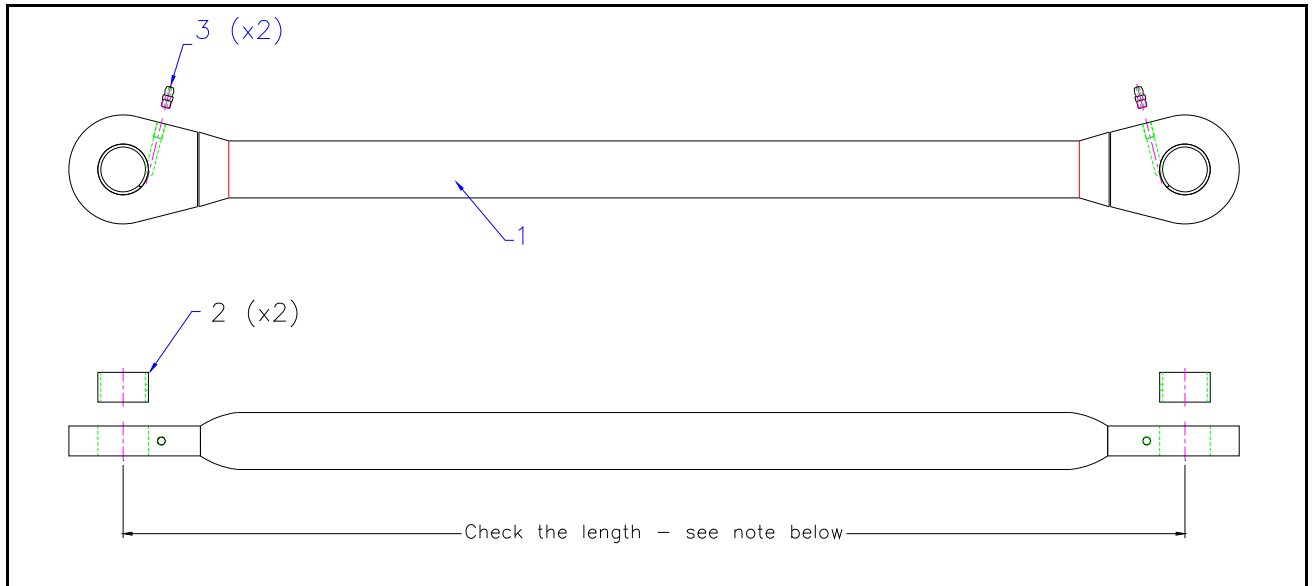

No.	Part No.	Part	Qty	Unit Price
	35 61 100 A	LONG LINK ROD ASSEMBLY (complete)	2	R1 373.65
1	* NSS	LONG LINK ROD WELDMENT	1	-
2	BPAP 3020 P20	PERMAGLIDE BUSH	2	R 74.80
3	MGN 08	GREASE NIPPLE M8	2	R 12.00

\* Not Sold Separately

## NOTE:

**The length of this link rod was revised late in 2006. Please call us at 021 386 0404 to determine the correct replacement parts.**

# LOWER LINK FRAME ASSEMBLY

Part Number 35 62 100 A

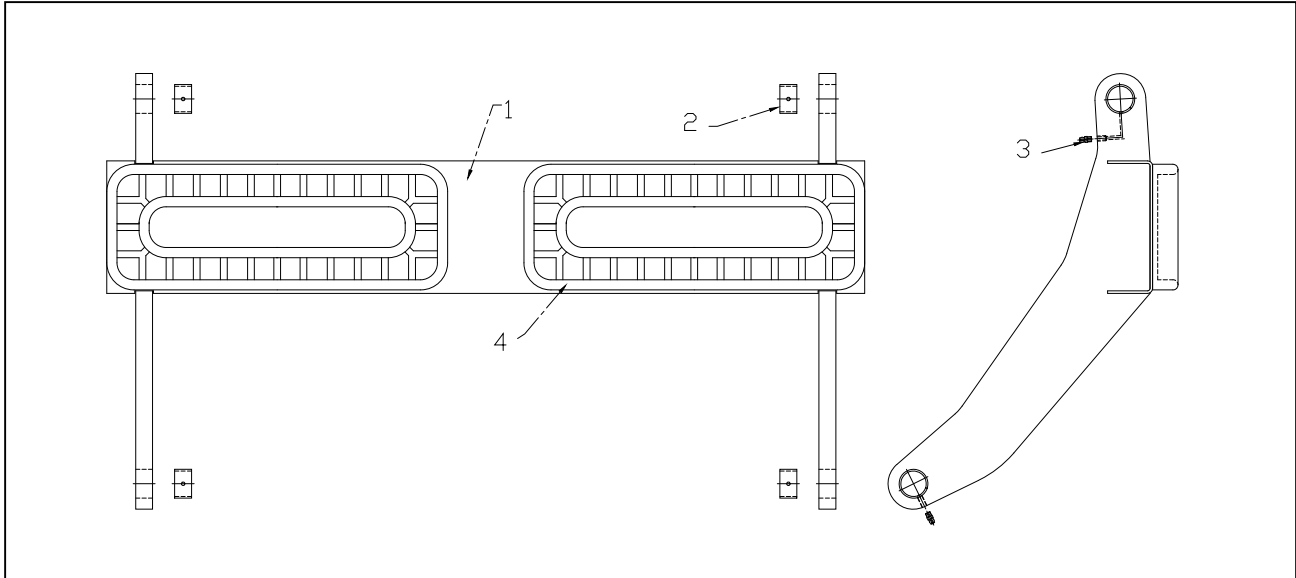

No.	Part No.	Part	Qty	Unit Price
	35 62 100 A	LOWER LINK FRAME ASSEMBLY (complete)	1	R6 283.70
1	* NSS	LOWER LINK FRAME WELDMENT	1	-
2	BPAP 3020 P20	PERMAGLIDE BUSH	4	R 74.80
3	MGN 08	GREASE NIPPLE M8	4	R 12.00
4	05.20.105R	RUBBER (Glue on)	2	R 367.50

\* Not Sold Separately

# SWING FRAME

Part Number: 35 70 000 A

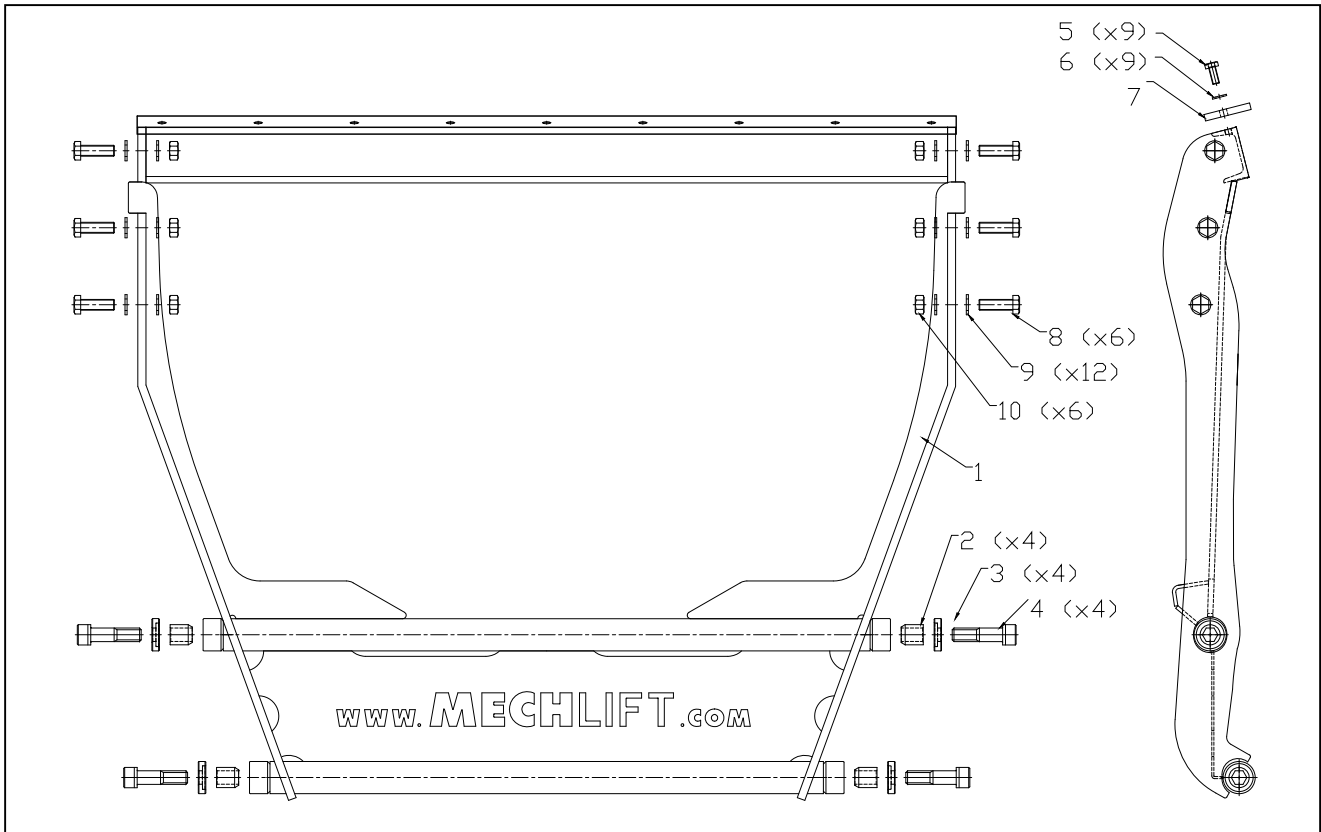

No.	Part No.	Part	Qty	Unit Price
	35 70 000 A	SWING FRAME ASSEMBLY (complete)	1	R 7 347.00
1	* NSS	SWING FRAME WELDMENT	1	-
kit	07 90 115 K	JOINT SERVICE KIT (incl item no's 2 to 4 & 30mm bush)	4	R 390.90
kit	07 90 116 K	KIT – Bolt and Nut (50mm x 6off)	1	R 122.55

\* Not Sold Separately

# MAIN FRAME ASSEMBLY

Part Number: 35 90 000 A

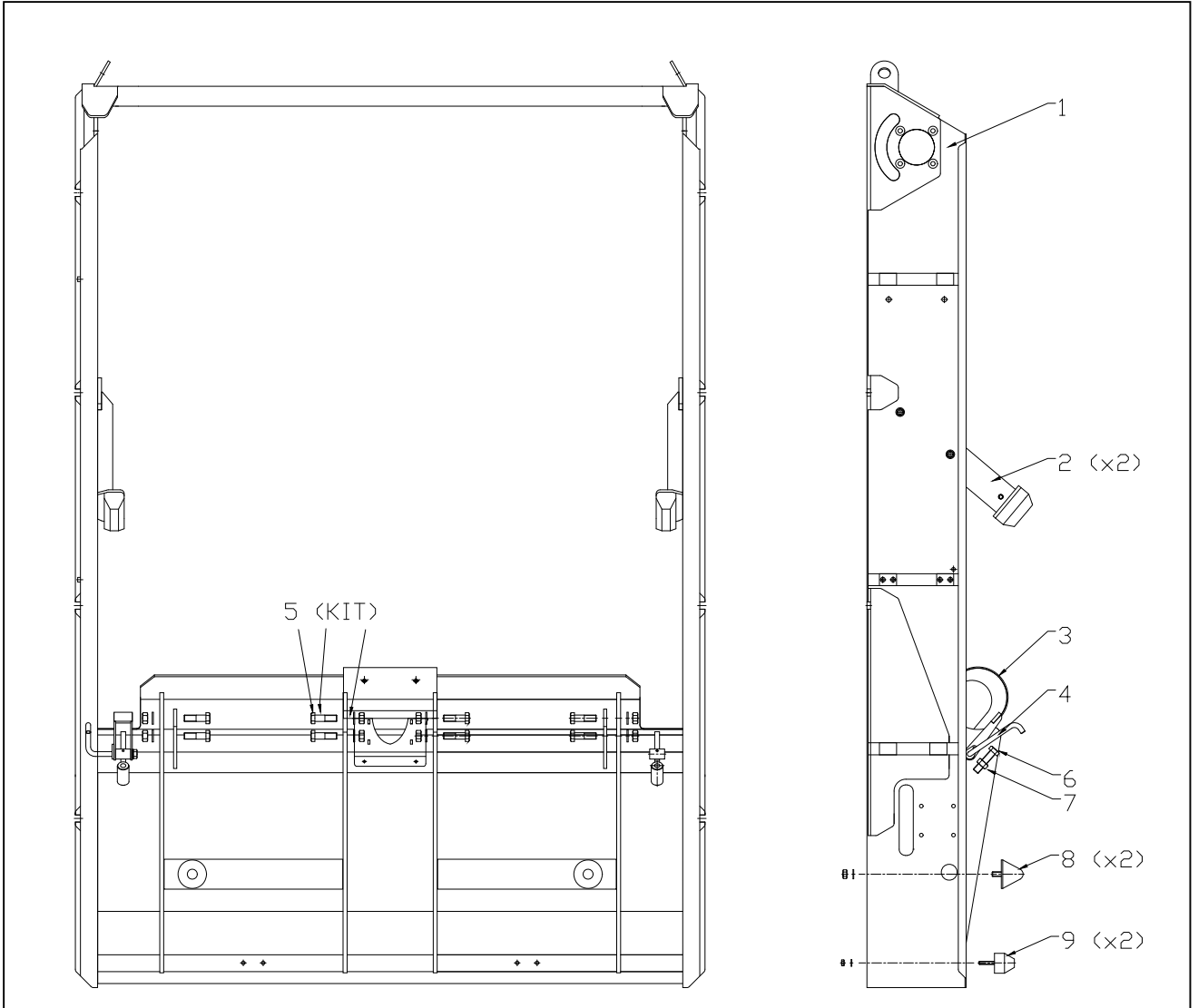

# FRAME CONTINUED

No.	Part No.	Part	Qty	Unit Price
1	35 90 000 A	FRAME ASSEMBLY (incl all items listed below)	1	R23 800.00
2	35 92 200 A	UPPER STOP BRACKET ASSEMBLY	2	Page 18
3	35 23 200 A	COUPLING RETAINER ASSEMBLY	1	Page 19
4	35 94 300 A	FULCRUM LOCK ASSEMBLY	1	Page 20
5	07 90 117 K	KIT – actuator fasteners	1	R170.35
6	FB 1665 H8ZP	STOP BOLT M16 x 65mm	2	*NSS
7	FN 16 ZP	NUT	2	*NSS
8	05 10 124 R	RUBBER BUFFER CONICAL 55mm (M12x24)	2	R196.70
9	05 10 319 R	RUBBER BUFFER RECTANGULAR 100x50 (M8)	2	R280.60

# UPPER STOP BRACKET

Part Number: 35 92 200 A

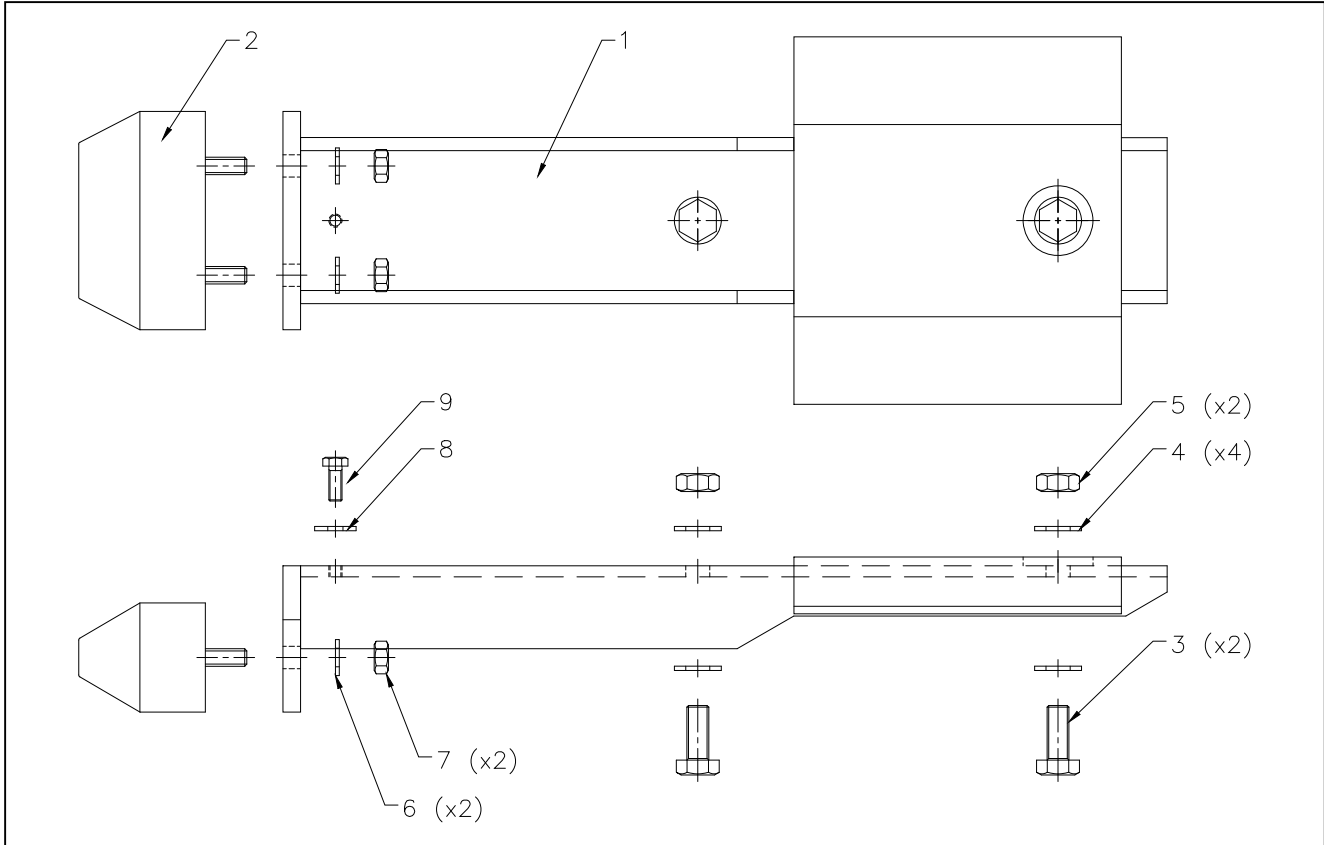

No.	Part No.	Part	Qty	Unit Price
	35 92 200 A	UPPER STOP BRACKET (complete)	2	R800.40
1	* NSS	UPPER STOP BRACKET WELDMENT	1	-
2	05 10 319 R	RUBBER BUFFER RECTANGULAR 100x50 (M8)	2	R280.60
3	FS1025H8ZP	SCREW M10x25	2	* NSS
4	FW 10	WASHER M10	4	* NSS
5	FN10 ZP	NUT M10	2	* NSS
6	FW 08	WASHER M8	2	* NSS
7	FN 08 ZP	NUT M8	2	* NSS
8	FWF 6319020	WASHER (1/4"ID x19mm OD x2mm)	1	* NSS
9	FS 0616 H8ZP	SCREW M6 x16	1	* NSS

\* Not Sold Separately

# COUPLING RETAINER ASSEMBLY

Part Number: 35 23 200 A

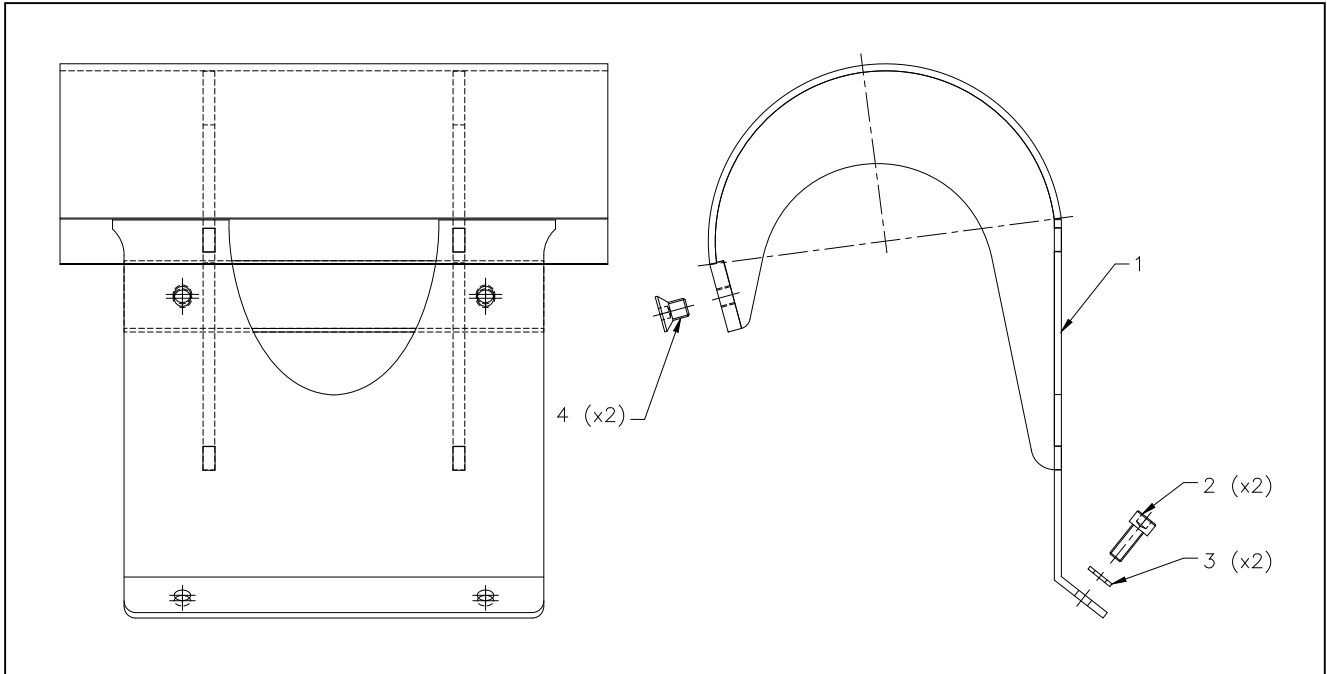

No.	Part No.	Part	Qty	Unit Price
	35 23 200 A	COUPLING RETAINING ASSEMBLY (complete as shown)	1	R627.15
1	* NSS	COUPLING RETAINER WELDMENT	1	-
2	FS 0616 AB	SCREW ALLEN CAP M6 x16 (BLACK)	2	* NSS
3	FW 08	WASHER M8	2	* NSS
4	FSCSK 0812 AB	SCREW CSK CAP SCREW M8 x12 (BLACK)	2	* NSS

\* Not Sold Separately

# FULCRUM LOCK ASSEMBLY

Part Number: 35 94 300 A

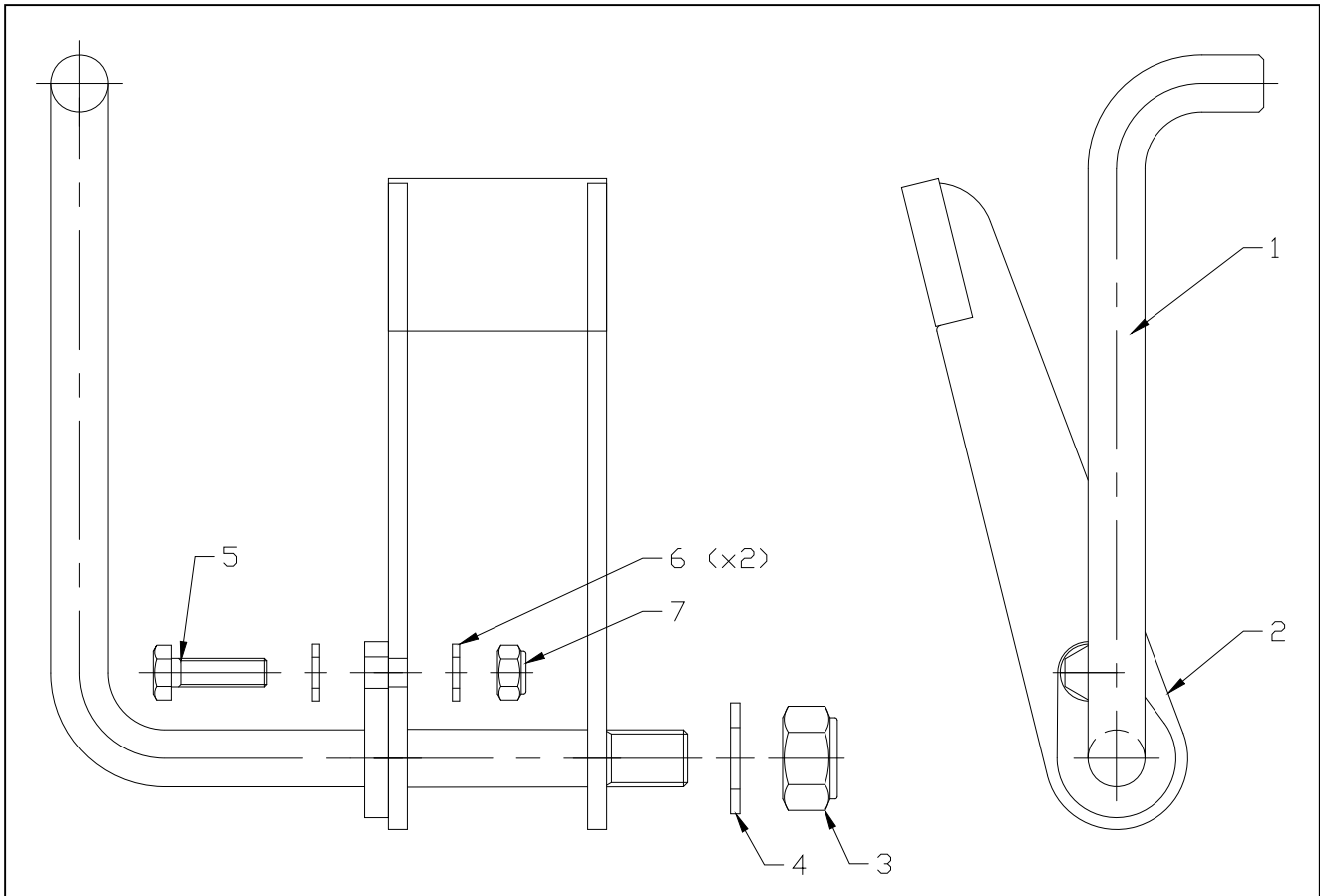

No.	Part No.	Part	Qty	Unit Price
	35 94 300 A	FULCRUM LOCK ASSEMBLY (complete)	1	R459.50
1	35 94 310 W	HANDLE WELDMENT	1	R244.70
2	35 94 300 W	LOCK WELDMENT	1	R203.00
3	FN 12 NL	NUT NYLOC M12	1	* NSS
4	FW 12	WASHER M12	2	* NSS
5	FS 0620 H8ZP	SCREW M6 x20	2	* NSS
6	FW 06	WASHER M6	2	* NSS
7	FN 06 NL	NUT NYLOC M6	1	* NSS

\* Not Sold Separately

# GUARD FRAME ASSEMBLY - LH

Part Number: 01 15 101 A

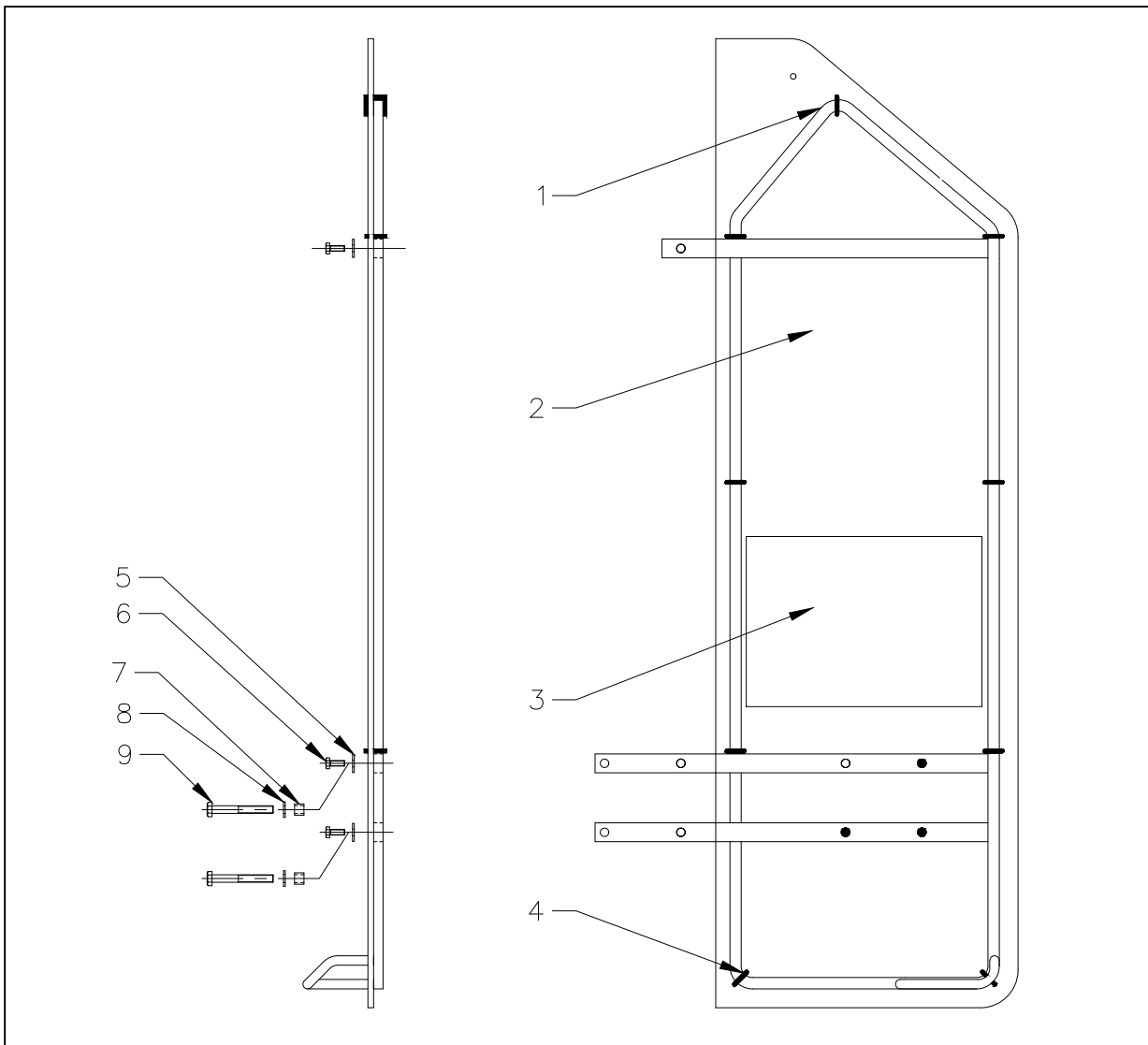

No.	Part No.	Part	Qty	Unit Price
	01 15 101 A	GUARD FRAME ASSEMBLY – LH (complete)	1	R1 740.00
1	01 15 121 E	GUARD FRAME – LH (Metal frame only)	1	R1 049.70
2	06 20 111 R	SCREEN (including decal) LH	1	R 658.00
3	09 10 135 X	DECAL	1	R 66.00
4	FTS 05200	TIE STRAP NYLON 5 x200mm	9	* NSS
5	FW 06	WASHER M6	5	* NSS
6	FS 0616 H8ZP	SCREW M6 x16	5	* NSS
7	03 20 212 S	SPACER BUSH	3	* NSS
8	FW 08	WASHER M8	3	* NSS
9	FB08065 H8ZP	BOLT M8 x65	3	* NSS

\* Not Sold Separately

# GUARD FRAME ASSEMBLY - RH

Part Number: 01 15 102 A

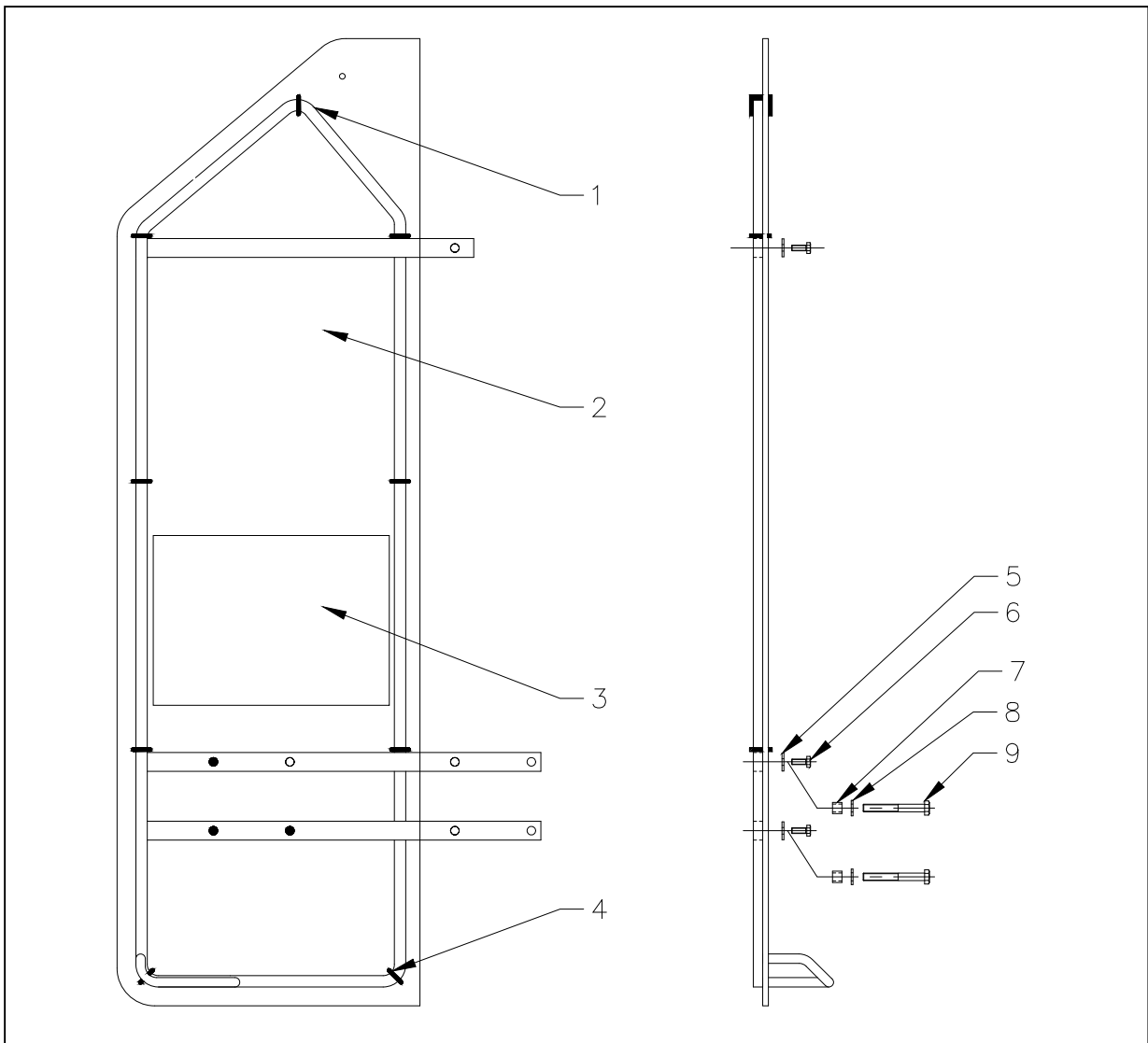

No.	Part No.	Part	Qty	Unit Price
	01 15 102 A	GUARD FRAME ASSEMBLY – RH (complete)	1	R1 740.00
1	01 15 122 E	GUARD FRAME – RH (Metal frame only)	1	R1 049.70
2	06 20 112 R	SCREEN (including decal) RH	1	R 658.00
3	09 10 135 X	DECAL	1	R 66..00
4	FTS 05200	TIE STRAP NYLON 5 x200mm	9	* NSS
5	FW 06	WASHER M6	5	* NSS
6	FS 0616 H8ZP	SCREW M6 x16	5	* NSS
7	03 20 212 S	SPACER BUSH	3	* NSS
8	FW 08	WASHER M8	3	* NSS
9	FB08065 H8ZP	BOLT M8 x65	3	* NSS

# STOPPER BAR ASSEMBLY

Part Number: 35 92 100 A

USED ON Model ML325 ONLY

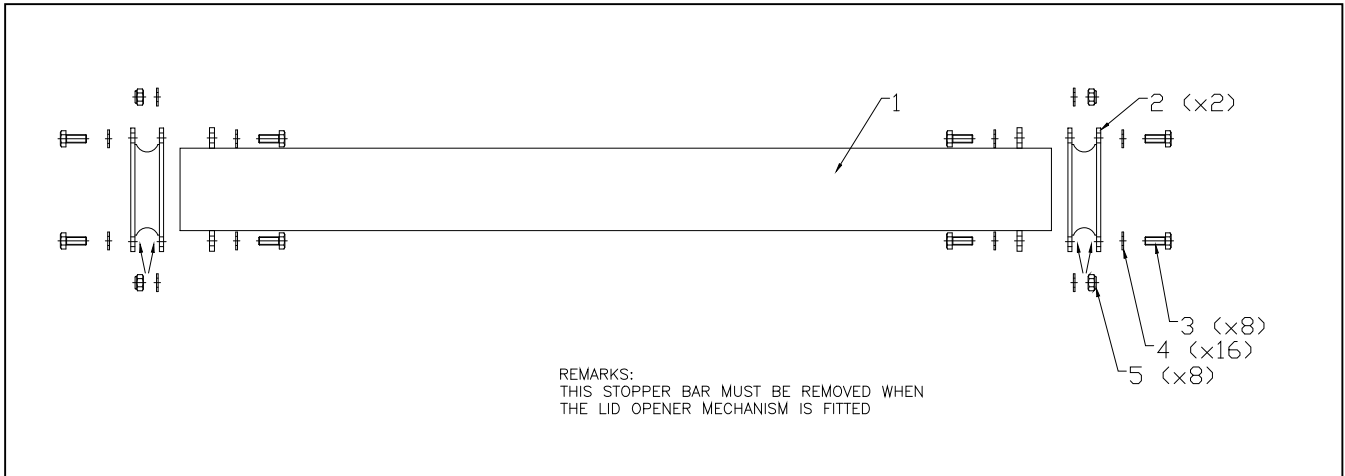

No.	Part No.	Part	Qty	Unit Price
	35 92 100 A	STOPPER BAR ASSEMBLY (complete)	1	R2 341.40
1	* NSS	STOPPER BAR WELDMENT	1	-
2	35 92 110 R	RUBBER	2	R 605.00
3	FS1025H8ZP	SCREW M10x25	8	* NSS
4	FW 10	WASHER M10	16	* NSS
5	FN10 NL	NUT NYLOC M10	8	* NSS

\* Not Sold Separately

# LID OPENER ASSEMBLY

Part Number: 35 93 001 A

USED ON Model ML325K ONLY

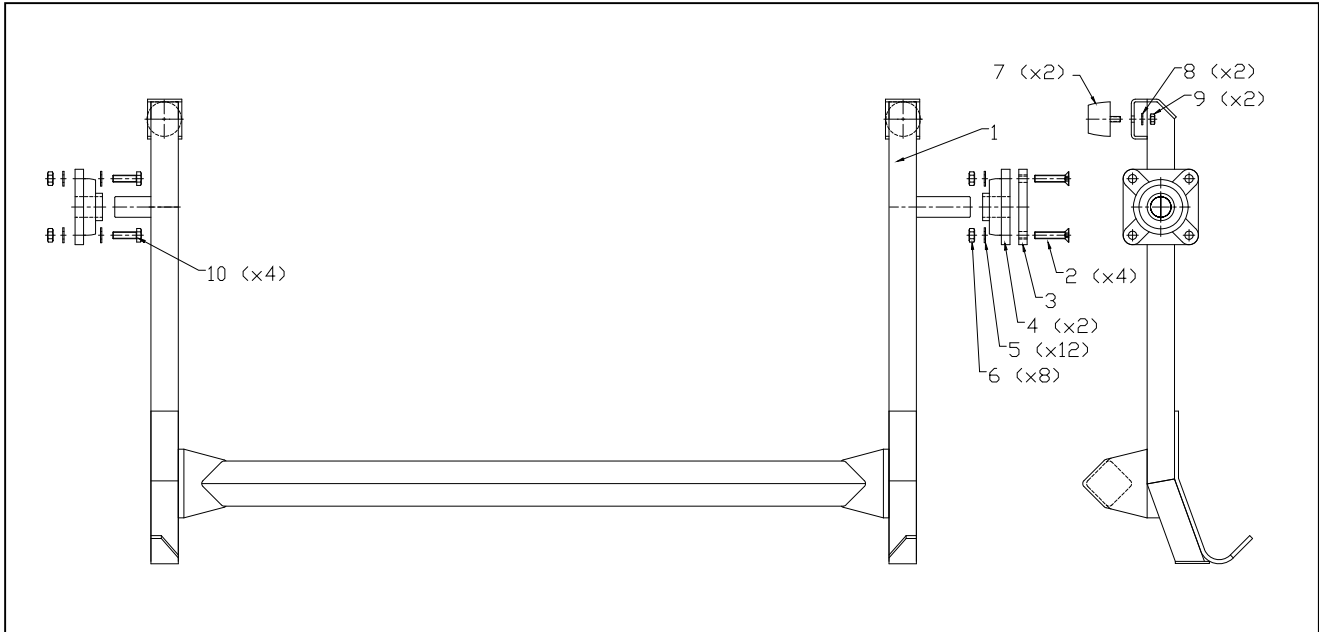

No.	Part No.	Part	Qty	Unit Price
	35 93 001 A	LID OPENER FRAME ASSY – Complete as shown Excluded is its Control Mechanism – See next page	1	R4 480.00
1	35 93 100 W	LID OPENER FRAME WELDMENT	1	R3 813.05
2	FSCSK 1050 AB	SCREW CSK CAPSCREW M10 x50	4	* NSS
3	35 93 205 P	BEARING SPACER	1	R 51.00
4	BUCF 206	FLANGE MOUNT BEARING	2	R 176.85
5	FW 10	WASHER M10	12	* NSS
6	FN 10 ZP	NUT M10	8	* NSS
7	05 10 232 K	KIT – Rubber buffer	2	R 145.00
10	FS 1035 H8ZP	SCREW M10 x35	4	* NSS

\* Not Sold Separately

# Lid Opener CONTROL MECHANISM

Part Number: 35 93 200 A  
USED ON Model ML325K ONLY

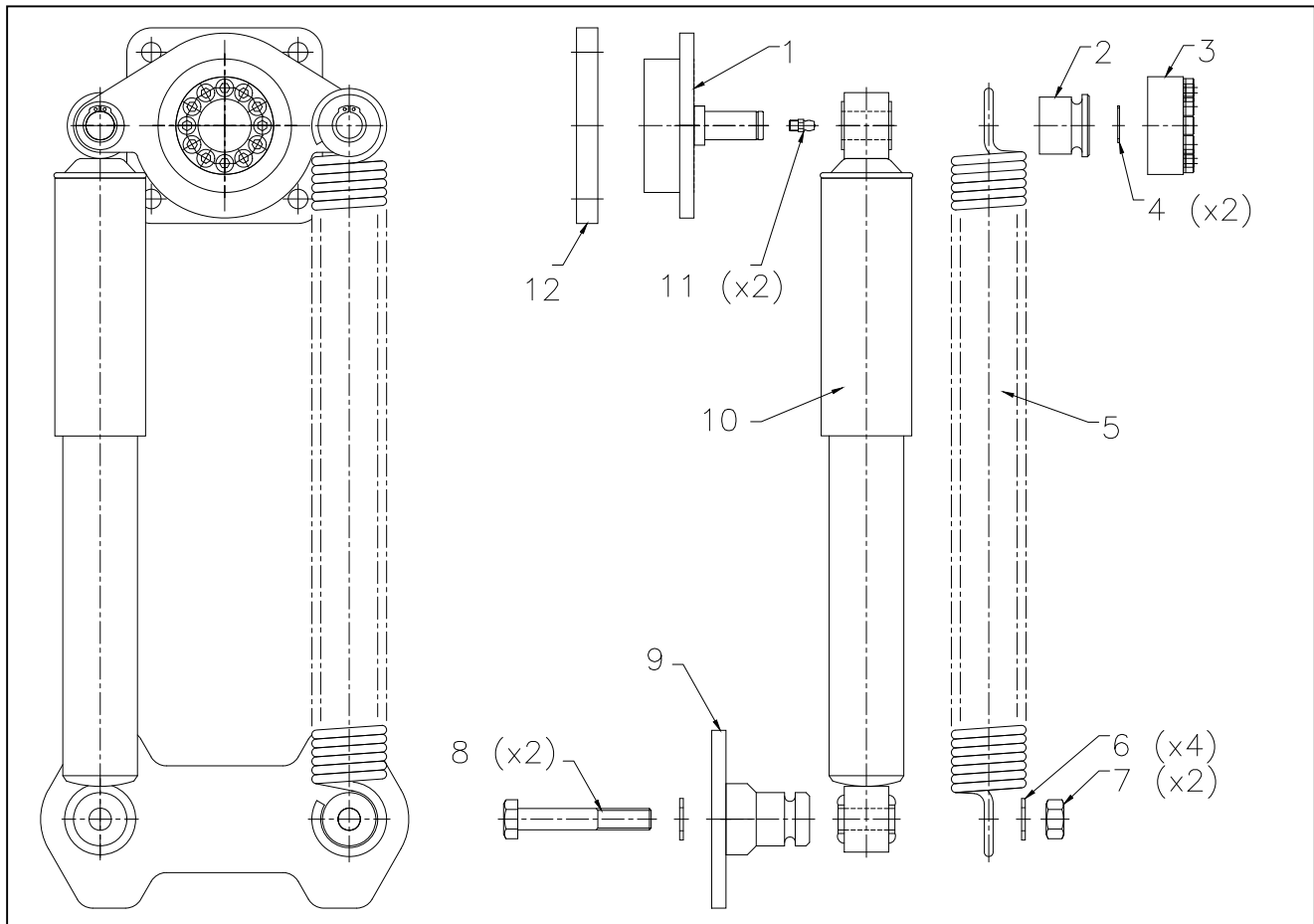

No.	Part No.	Part	Qty	Unit Price
	35 93 200 A	LID OPENER CONTROL MECHANISM -COMPLETE	1	R2 935.00
1	35 93 210 W	BELLCRANK WELDMENT	1	R 670.70
2	06 40 021 T	BUSH	1	R 180.42
3	FCONEX 30	QUANTUM 30 30x55	1	R 452.00
4	FC 16 E	CIRCLIP DIAMETER 16mm EXTERNAL	2	R 10.00
5	04 10 006 E	SPRING - PLATED	1	R 375.00
6	FW 12	WASHER M12	4	* NSS
7	FN 12 NL	NUT NYLOC M12	2	* NSS
8	FB 1275 H8ZP	BOLT M12 x75	2	* NSS
9	35 93 220 W	MOUNTING PLATE WELDMENT	1	R 476.70
10	35 93 230 D	DAMPER	1	R 743.55
11	MGN 06	GREASE NIPPLE M6	2	* NSS
12	35 93 205 P	BEARING SPACER	1	R 51.00

\* Not Sold Separately

# BIN OPENER PULL BACK KIT

Part Number: To be advised

Required for 1100litre bins with flat lids on a comb pick up. For these the sprung lid opener must be pulled back, hence this kit.

Consists of a handle, cable and bracketing

No diagram yet - details available from  
Mechlift

No.	Part No.	Part	Qty	Unit Price
1	35 93 140 W	HANDLE	1	*POA
2	35 90 103 X	Wire Rope 4mm Stainless Steel	1	*POA
3	35 90 104 X	Cable clamps 4mm	2	*POA
4	35 90 106 X	Thimble 5mm Stainless steel	2	*POA
5	35 90 107 X	Shackle 8mm Galv 'D	2	*POA

\*Price on application

# KLAPARM KIT

Part Number: 35 90 003 A

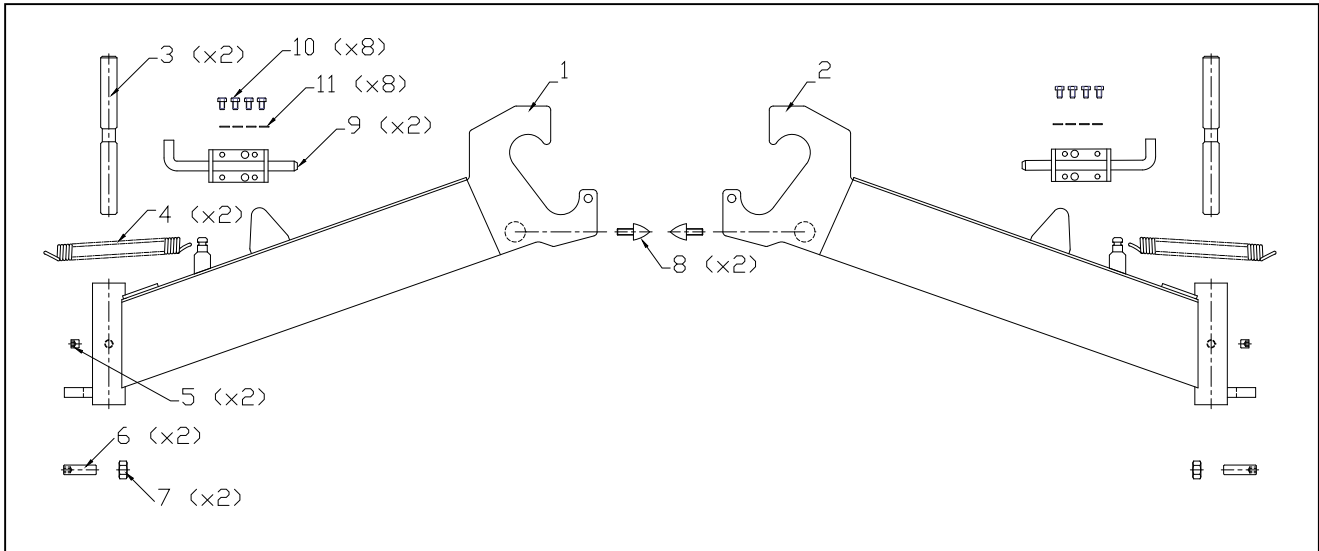

No.	Part No.	Part	Qty	Unit Price
	35 90 003 A	KLAPARM KIT Complete excl Sliding Bolts	1	R7 785.00
1	35 53 101 W	BIN CARRIER ARM - LH	1	R3 000.00
2	35 53 102 W	BIN CARRIER ARM - RH	1	R3 000.00
3	31 53 010 T	KLAPARM HINGE PIN	2	R 345.00
4	04 10 003 E	SPRING - KLAPARMS	2	R 130.00
5	FSG 1012 ZP	SCREW GRUB M10 x 12	2	* NSS
6	FSG 1240 ZP	SCREW GRUB M12 x 40	2	* NSS
7	FN 12 ZP	NUT M12	2	* NSS
8	MCR 205	RUBBER BUFFER RPM 205	2	R 72.00
9	MSB164	SLIDING BOLT – Spring loaded	2	R 111.00
10	FS 0610 ZP	SCREW M6 x 10	8	* NSS
11	FW 06	WASHER Ø6	8	*NSS

\* Not Sold Separately

# HYDRAULIC SYSTEM

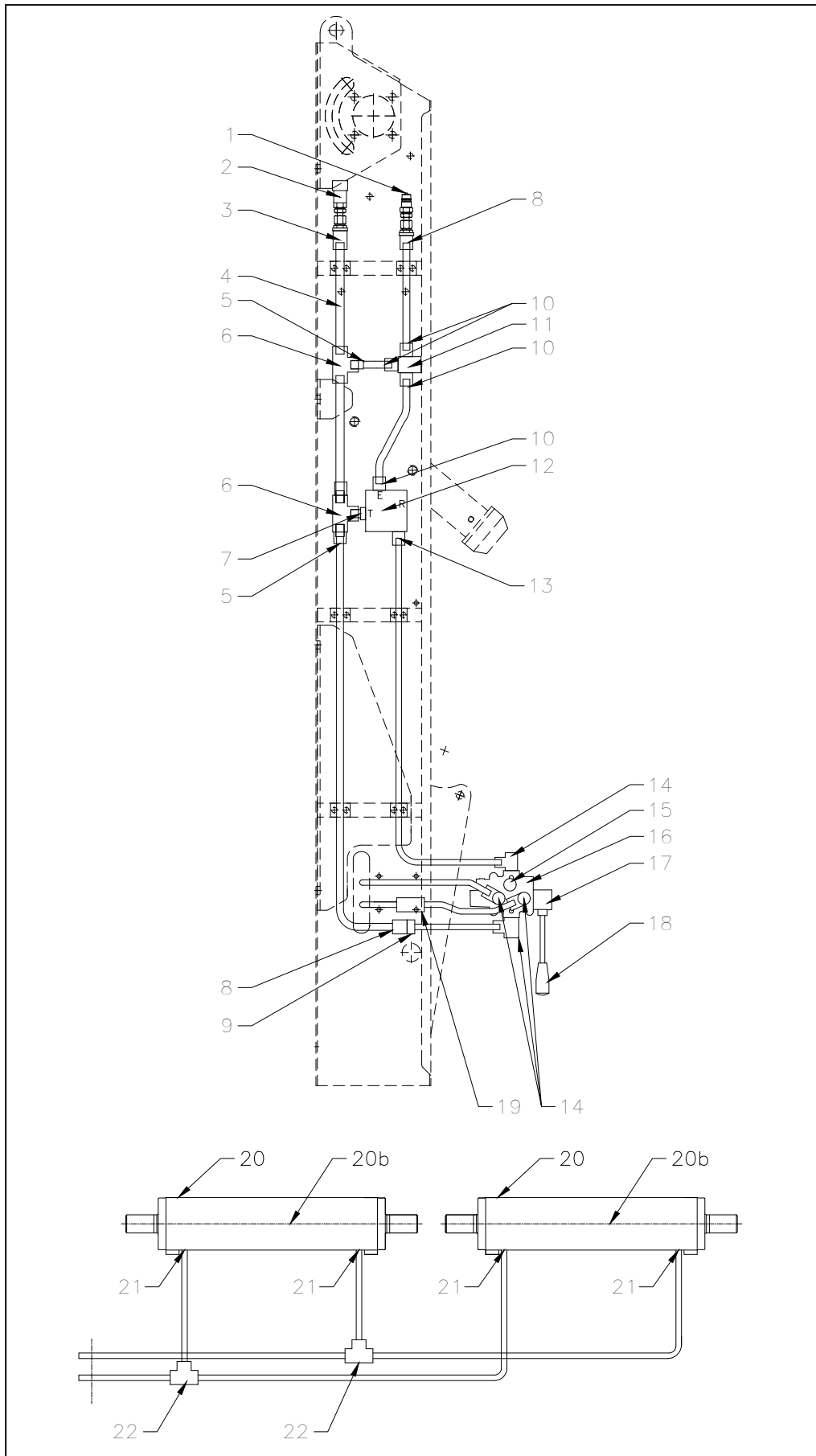

# HYDRAULIC SYSTEM CONTINUED

No.	Part No.	Part	Qty	Unit Price
1	HCM12 5.ISO	MALE QUICK COUPLER ½ “	1	R 96.70
2	HCF12 5.ISO	FEMALE QUICK COUPLER ½ “	1	R 205.85
3	HG.18.L	STRAIGHT COUPLING 18mm	1	*NSS
4	35 10 000 E	HYDRAULIC PIPE SET	1	R1 482.80
4a	35 10 001 SP	INDIVIDUAL PIPE (NON PLATED)	1	R 175.00
5	HRED.18/15.L	REDUCING STANDPIPE	2	*NSS
6	HT.18.L	TEE COUPLING	2	*NSS
7	HEVGE.18.LR.ED	STANDPIPE STRAIGHT STUD	1	*NSS
8	HG.15.L	STRAIGHT COUPLING 15mm	2	*NSS
9	HRED.15/12.L	REDUCING STANDPIPE	1	*NSS
10	HGE.15.LR.ED	STRAIGHT MALE STUD FITTING	4	*NSS
11	HV.MAIN.RELIEVE	MAIN RELIEF VALVE	1	R 900.00
12	HV.FLO.REG 50	FLOW REGULATOR	1	R2 440.00
13	HGE.12.PLR.1/2.ED	STRAIGHT MALE STUD ½ TO 12mm	1	*NSS
14	HWH.12LR	BANJO COUPLING WH.12LR	4	*NSS
15	HMINI3.8	MINITEST COUPLING – 3/8” BSP -ED	1	R 241.00
16	HV.VCD20.LH	CONTROL VALVE LH (Includes Lever Box but excludes Fittings & Handle)	1	R2 576.00
17	HV.VCD.BOX	LEVER BOX ASSEMBLY (shaped square)	1	R 252.00
17b	HV.VCD.CAP	END CAP ASSY (shaped round & spring side)	1	R 172.00
18	01 40 010 R	VALVE HANDLE	1	R 140.00
19	HV.FLO.REST.35	FLOW RESTRICTOR (Drilled 3.5mm)	1	R 222.00
20	08 10 140 X	S2241 ACTUATOR	2	R35 717.20
20b		SEAL KIT – S2241	1	See next page
21	03 70 001 E	SPECIAL FITTING – Actuator Port	4	R 139.40
22	HT.12.L	TEE COUPLING	2	*NSS

\* Not Sold Separately

# ACTUATOR SERVICE PARTS

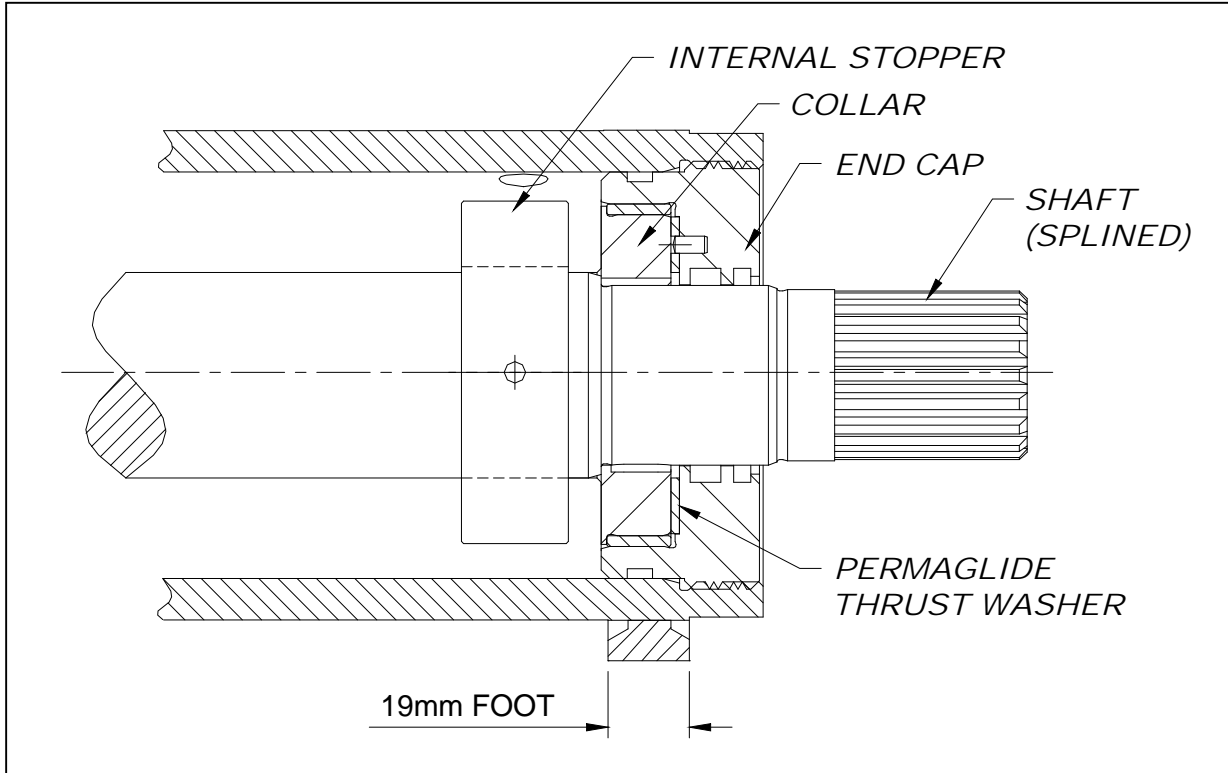

Part No.	Part	Qty	Unit Price
08 10 140 X	ACTUATOR Model S2241	1	R35 717.22
A SKH22 000	SEAL & BRG KIT – For full overhaul (Genuine OEM) (includes stopper , thrust washers and seals)	1	R5 361.45
A SKH22 300	SEAL KIT – End cap side only (Genuine OEM) (includes wiper, seal, o’ring, backup ring)	2	R862.40
06 10 241 T	ACTUATOR INTERNAL STOPPER <b>(use only genuine OEM part)</b>	1	R411.75
BPAW 62 P10	THRUST WASHER	2	R409.60
--	SHAFT – EURO S2241 (ex works only)	1	POA
--	COLLAR ( only sold as part of End Cap below )	2	--
08 10 144 X EC	END CAP Complete with collar, seals, thrust washer	2	R4 445.00

***NB***

Observe internal timing marks ***BEFORE*** pulling piston and shaft from barrel

# Contact information:

Please feel free to contact us should you have any queries or need any further information:

Telephone:	+27 (0) 21 386 0404
Fax:	+27 (0) 21 385 1886
E-mail:	info@mechlift.com
Web address:	www.mechlift.com
Physical Address:	84 Mobile Road Airport Industria Cape Town 7490 South Africa
Postal Address:	84 Mobile Road Airport Industria Cape Town 7490 South Africa

**Please Note:**

This spare parts book is valid for the period: **1<sup>st</sup> January 2011 till 31<sup>st</sup> December 2011.**

The given price reflects the price for each unit, part or kit, some assemblies may require more than one of the same unit, part or kit. Mechlift (Pty) Ltd reserves the right to change prices and /or part numbers without notification.

**Copyright ©**

This publication, or parts thereof, may not be reproduced in any form, by any method, for any purpose, without prior written permission from Mechlift (Pty) Ltd.

**Liability**

Whilst every attempt has been made to assure the accuracy of this manual, Mechlift (Pty) Ltd cannot accept responsibility for any errors, which may occur.

All information given is subject to change without notice.



