

DIMENSIONS:

MECHLIFT 220

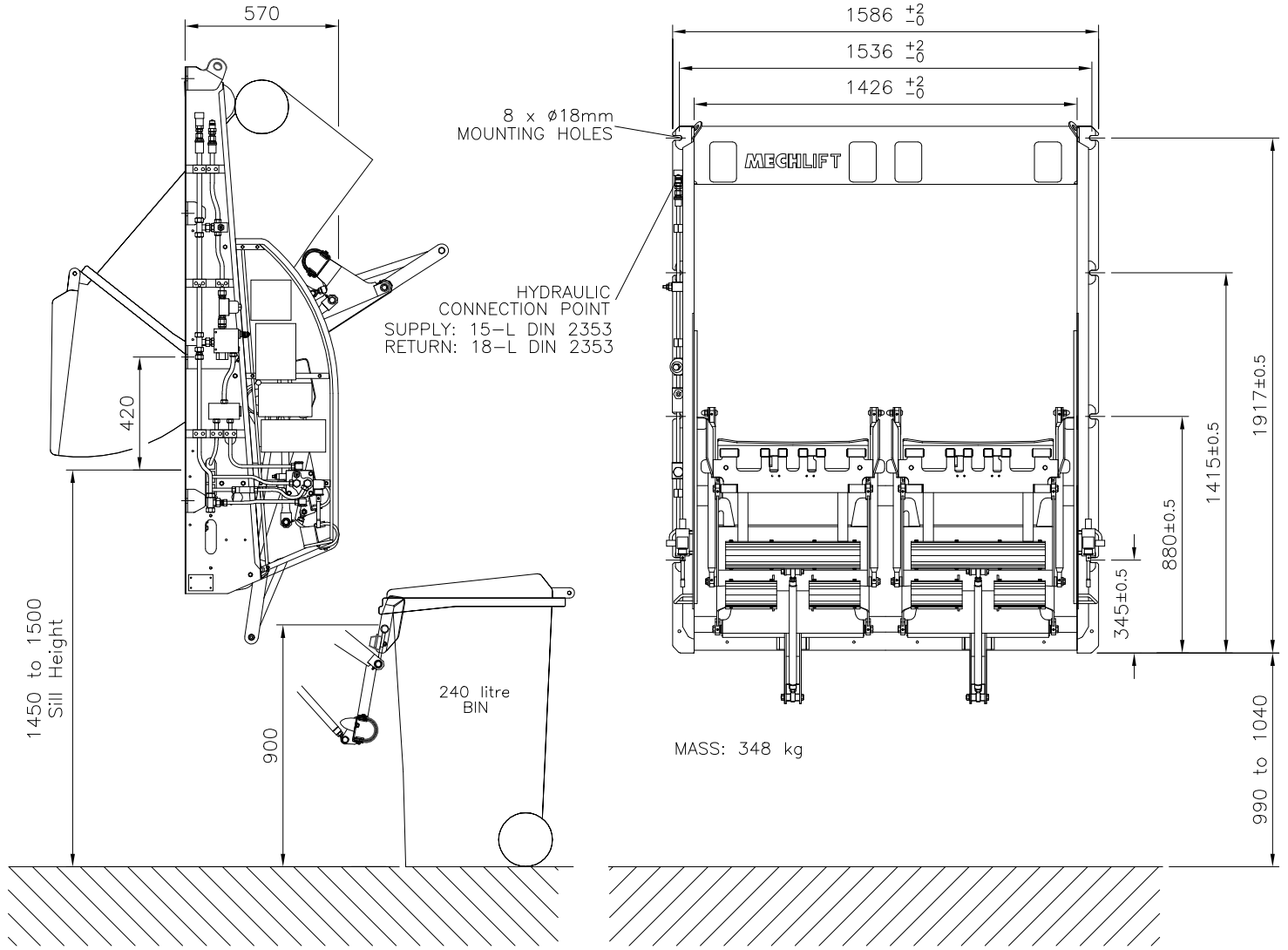

SPECIFICATIONS:

BIN TYPE: 2 X 240 litre per lifter  
 CYCLE TIME: 7 – 8 seconds  
 TIPPING ANGLE: 55 degrees  
 LIFTING CAPACITY: 2 X 150 Kg (adjustable limit)  
 (exceeds bin rating by 50%)  
 HYDRAULIC PRESSURE: 130 bar  
 (relief valve set at 150 bar)  
 HYDRAULIC FLOW: 18 litre/min for 8 sec. cycle time  
 NOISE LEVEL: < 72 dBA

OPTIONS:

1. Electronic monitoring and counting of the lifts, etc.
2. Dual controls fitted to left hand side of the lifter.

FEATURES:

The Model 220 has maintenance-free bearings, no flexible hoses (all zinc-plated steel pipes), no exposed cylinder rods which could be damaged or ingest dirt.

Damage in the event of accidents are inexpensive to repair because of this models very simple design, which also makes it easy to be maintained.